

## Chapter 4: Gravity-Powered Systems

### Lawrence Tseung's COP=3.4 Pulsed-Flywheel Generator.

It is generally not realised that excess energy can be obtained from pulsing a flywheel or other gravitational device.



This fact has recently been stressed by Lawrence Tseung who refers to the extra energy obtained in this way as being "Lead-out" energy. This gravitational feature has been part of university Engineering courses for decades, where it has been taught that the loading stress on a bridge caused by a load rolling across the bridge is far less than the stress caused if that same load were suddenly dropped on to the bridge.

This impulse technology has been known for some time and it is demonstrated driving a canoe in the video at <http://www.youtube.com/watch?v=XMhAldgHOCs> but Lawrence points out the potential for using it as a method for gaining excess energy for practical use. In October 2009, Lawrence and his band of helpers ran public demonstrations of an early prototype electrical pulsing system which produces excess output energy of COP = 3.3, that is, with 3.3 times more output energy than the user has to put into it to make it work:

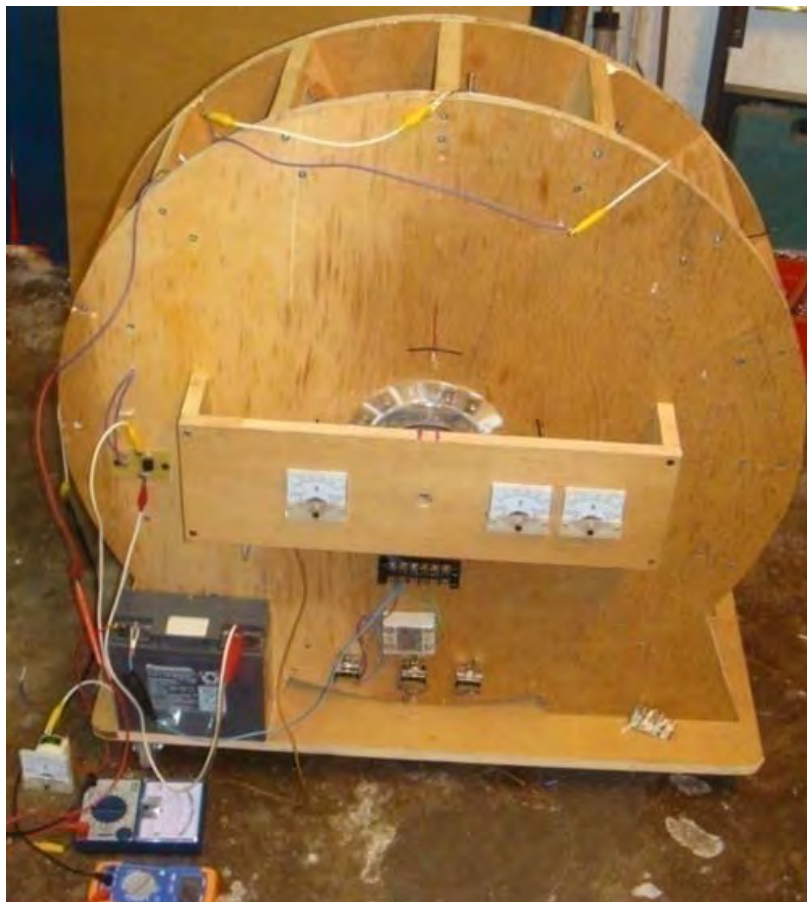

Video: [http://www.youtube.com/watch?v=tiafQ9R-REs&feature=mfu\\_in\\_order&list=UL](http://www.youtube.com/watch?v=tiafQ9R-REs&feature=mfu_in_order&list=UL) Lawrence is busy developing this device further as he intends to construct one with a output energy excess of several kilowatts.

Behind this device is Lawrence's "Lead-out" theory and for this he suggests a simple arrangement to demonstrate the principle. He presents the case of a rotor which has two substantial weights contained in two cylinders attached to the rotor:

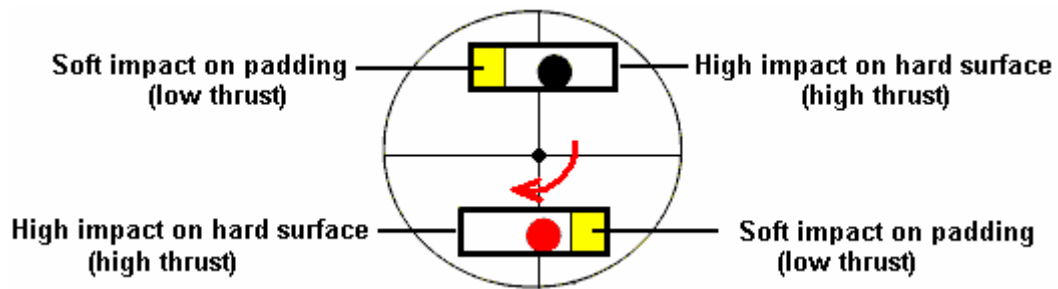

As the disc rotates, the ball falls down the length of the tube. At one end, the tube has a rigid cap which causes a significant impact when the ball hits it. The other end of the tube is padded and that cushions the impact which causes a net imbalance in the impacts and that maintains the rotation.

There is a prototype implementation on YouTube but the implementation is not adequate and the disc stops rotating after five minutes. The YouTube video slot is located at: <http://www.youtube.com/watch?v=zykButGc22U&feature=related> and there are two significant problems with that particular build. Firstly, the tube rotation is too slow to be effective and instead of the weight falling under gravity and accelerating to a good speed before the impact, the weight just rolls gently down a minor slope and does not make a major impact.

Secondly, the weights are far too small for the size of the wheel and there are only two weights providing impacts very widely spaced apart as the wheel rotates only slowly. One man made a ten-foot version and it rotated steadily for ten months after which time his wife insisted that it be taken apart as it was too noisy.

I would suggest some modifications to the wheel as Lawrence is far too busy with developing his COP>1 pulse implementation. Firstly, the movement of each weight should be delayed until the tube is much nearer the vertical. This can be achieved by curving part of the tube like this:

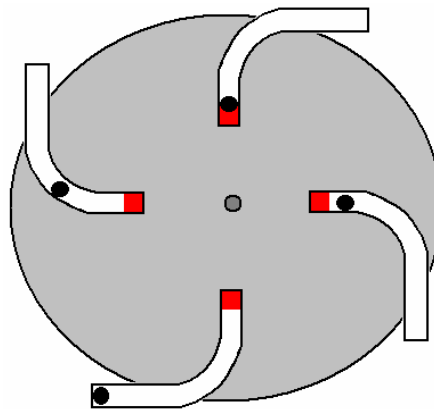

This way, the ball does not start rolling until the main part of the tube is near vertical. This allows a much greater acceleration and impact. The weighted ball should be much larger, say 2" (50 mm) in diameter and made of lead, in order to generate a significant thrust. Also, the cushioned ends of the tubes should be aligned with the pivot of the wheel so that any residual impact does not generate a turning force in the wrong direction. There is a negative turning effect due to the lever arm of the bottom weight. This turning force is only there for a small arc of rotation as the weight will roll inwards as soon as the tube section rises above the horizontal and as the tube then transitions into a circular curve, the movement inwards is gentle. It probably would be better if the tubes were angled slightly more in the clockwise direction, rather than exactly as shown in the diagram.

Secondly, there should be eight tubes on the disc, four on each side and one side staggered by 45 degrees so that there is a driving impact every 45 degrees instead of the 180 degrees of the version shown in the YouTube video. With that arrangement of four times as many impacts, each substantially greater, and no significant reverse impacts, the wheel has a much better chance of successful rotation without needing to be particularly large. The wheel itself should not be light as it acts as a flywheel and a pulsed flywheel has

already been shown to produce excess power. The wheel bearings should be ball races and not the closed variety because those ones are packed with grease and have a serious resistance to rotation. Instead, the open-sided variety of ball bearing should be used as they rotate very freely.

Using straight tubes for illustration, each tube could be like this:

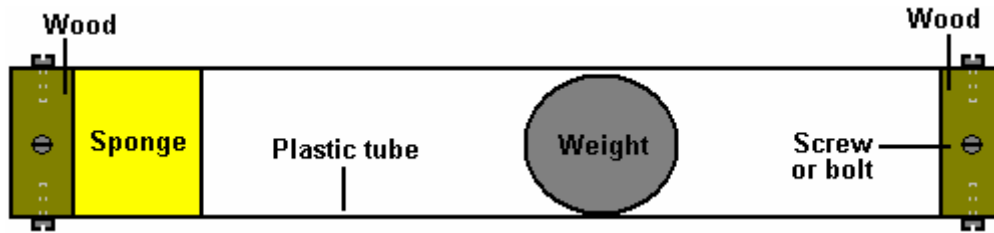

Here, a wood disc is fitted to each end of a piece of plastic tube and held securely in place with screws or bolts which pass through small holes drilled in the plastic pipe and screw into the wooden disc. A piece of thick sponge is glued to the disc at one end and the heavy weight inside the tube is not a tight fit so that it can move very freely inside the tube. Four of these tubes are fitted to each side of each disc used in the device as shown here:

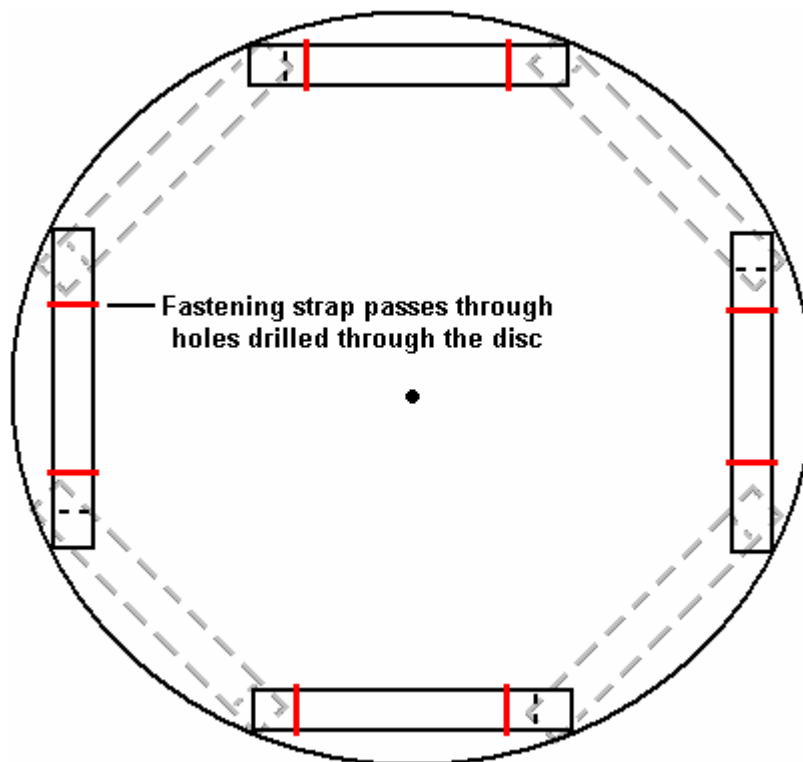

The four tubes attached to the back of the disc are 45 degrees away from the tubes mounted on the front of the disc. Each tube is attached securely in place with straps which pass through the disc and are secured on the far side. The tubes can also be glued in place to further strengthen the attachment. These eight tubes give an unbalanced impact for every 45 degrees of rotation. If two of these discs are attached to a common rotor shaft, then the second disc can be positioned 22.5 degrees around from the first one. That arrangement gives an unbalanced impact for every 22.5 degrees of rotation. If three discs were placed on a common rotor shaft and evenly positioned, then there would be an unbalanced impact every 15 degrees of rotation, which is 24 impacts per rotation. A two-disc arrangement might look like this:

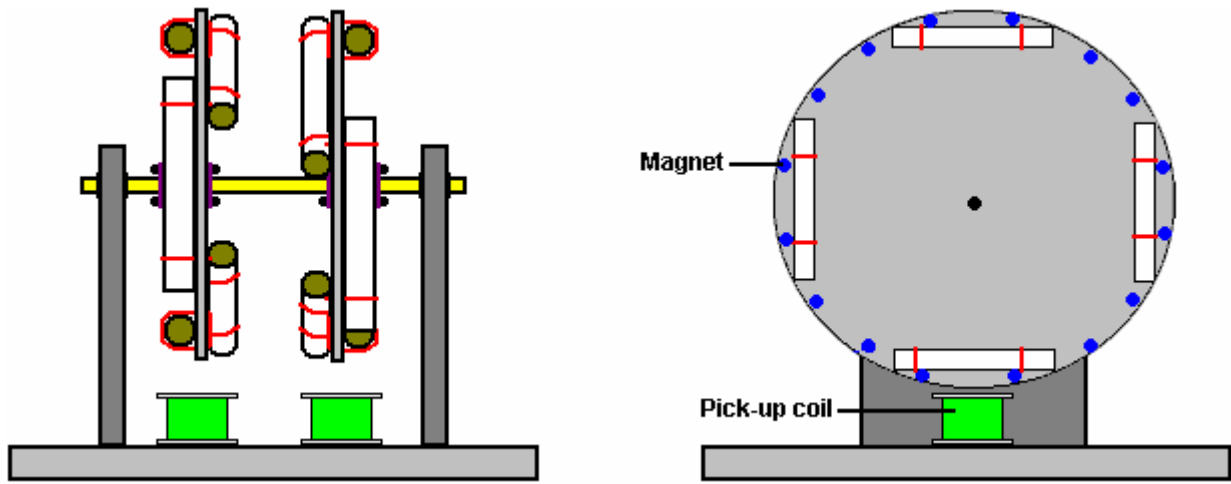

If the rotor spins well, then it would be worth while attaching a series of magnets to the discs, being careful to keep each disc perfectly balanced. One or more air-core coils can then be used to determine if current can be drawn from the device without stopping the rotation. The coils should not have a magnetic core as that would cause a major drag on the rotation whether current was being drawn or not.



**Chas Campbell's Flywheel System.**

Recently, Mr. Chas Campbell of Australia demonstrated electrical power gain with a flywheel system which he developed:

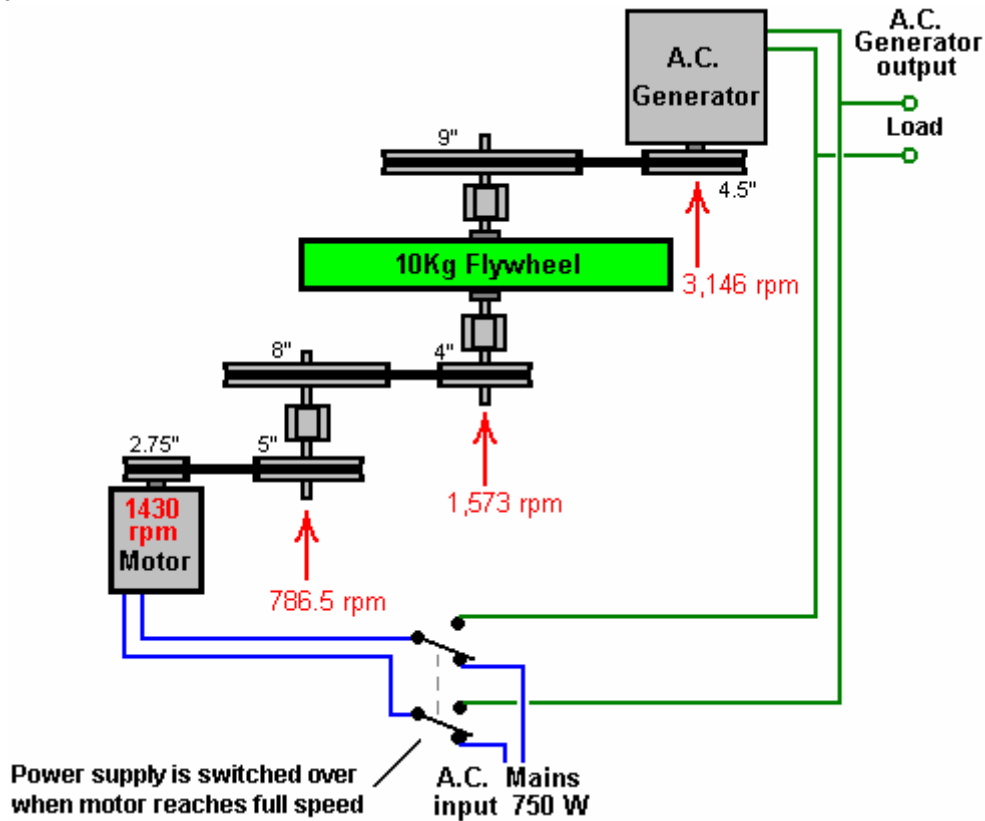

But what this diagram does not show, is that a couple of the drive belts are left with excessive slack. This causes a rapid series of jerks in the drive between the mains motor and the flywheel. These occur so rapidly that they do not appear noticeable when looking at the system operating. However, this stream of very short pulses in the drive chain, generates a considerable amount of excess energy drawn from the gravitational field. Chas has now confirmed the excess energy by getting the flywheel up to speed and then switching the drive motor input to the output generator. The result is a self-powered system capable of running extra loads.

Let me explain the overall system. A mains motor of 750 watt capacity (1 horsepower) is used to drive a series of belts and pulleys which form a gear-train which produces over twice the rotational speed at the shaft of an electrical generator. The intriguing thing about this system is that greater electrical power can be drawn from the output generator than appears to be drawn from the input drive to the motor. How can that be? Well, Mr Tseung's gravity theory explains that if a energy pulse is applied to a flywheel, then during the instant of that pulse, excess energy equal to  $2mgr$  is fed into the flywheel, where "m" is the mass (weight) of the flywheel, "g" is the gravitational constant and "r" is the radius of the centre of mass of the flywheel, that is, the distance from the axle to the point at which the weight of the wheel appears to act. If all of the flywheel weight is at the rim of the wheel, the "r" would be the radius of the wheel itself.

This means that if the flywheel (which is red in the following photographs) is driven smoothly at constant speed, then there is no energy gain. However, if the drive is not smooth, then excess energy is drawn from the gravitational field. That energy increases as the diameter of the flywheel increases. It also increases as the weight of the flywheel increases. It also increases if the flywheel weight is concentrated as far out towards the rim of the flywheel as is possible. It also increases, the faster the impulses are applied to the system.

However, Jacob Bitsadze points out that another mechanism comes into play even if all of the belts are correctly tensioned. The effect is caused by the perpetual inward acceleration of the material of the flywheel due to the fact that it rotates in a fixed position. He refers to it as being 'the rule of shoulder of Archimedes' which is not something with which I am familiar. The important point is that Chas Campbell's system is self-powered and can power other equipment.

Now take a look at the construction which Chas has used:



You notice that not only does he have a heavy flywheel of a fair size, but that there are three or four other large diameter discs mounted where they also rotate at the intermediate speeds of rotation. While these discs may well not have been placed there as flywheels, nevertheless, they do act as flywheels, and each one of them will be contributing to the free-energy gain of the system as a whole.

If the drive motor were a DC motor which is deliberately pulsed by a special power supply, then the effect is likely to be even greater. Chas' system produces excess energy, and although it is by no means obvious to everybody, that excess energy is being drawn from gravity. At this time, one of the videos of Chas operating his device can be seen at: [http://www.youtube.com/watch?v=8QD2Whs\\_LxA](http://www.youtube.com/watch?v=8QD2Whs_LxA).

Ok, so what are the requirements for an effective system? Firstly, there needs to be a suitable flywheel with as large a diameter as is practical, say 4 feet or 1.2 metres. The vast majority of the weight needs to be close to the rim. The construction needs to be robust and secure as ideally, the rate of rotation will be high, and of course, the wheel needs to be exactly at right angles to the axle on which it rotates and exactly centred on the axle:

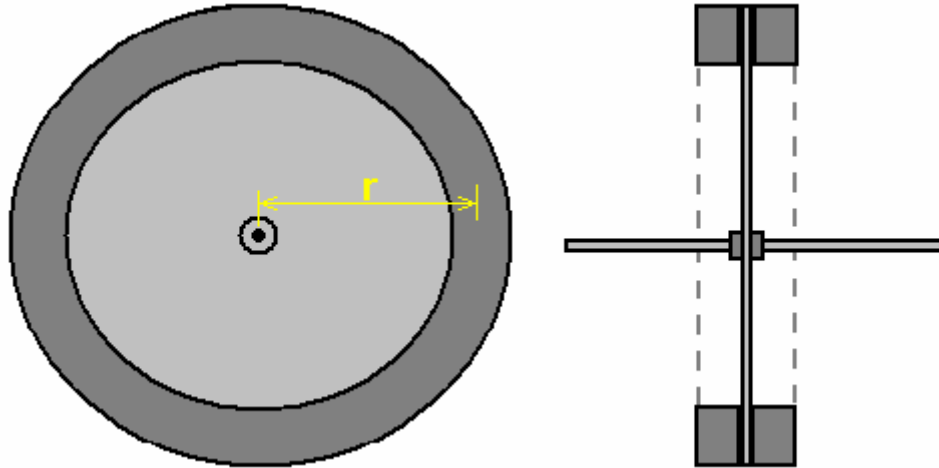

Next, you need a motor drive which gives a rapid pulsed drive to the shaft. This could be one of many different types. For example, the original motor design of Ben Teal where very simple mechanical contacts power simple solenoids which operate a conventional crankshaft with normal connecting rods:

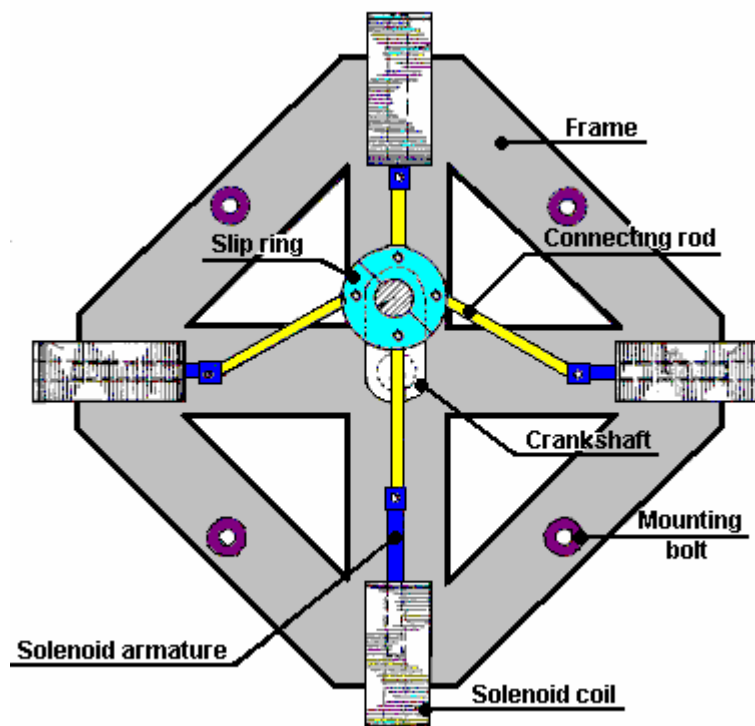

This style of motor is simple to construct and yet very powerful. The switch for each solenoid can be a very simple mechanical switch which is pushed closed by a cam when the crankshaft is in the position where the

solenoid should pull, and opens again when the crankshaft reaches the position where the solenoid should stop pulling. This motor also meets the requirement for rapidly repeated impulses to the axle of the flywheel. The motor power can be increased to any level necessary by stacking additional solenoid layers along the length of the crankshaft:

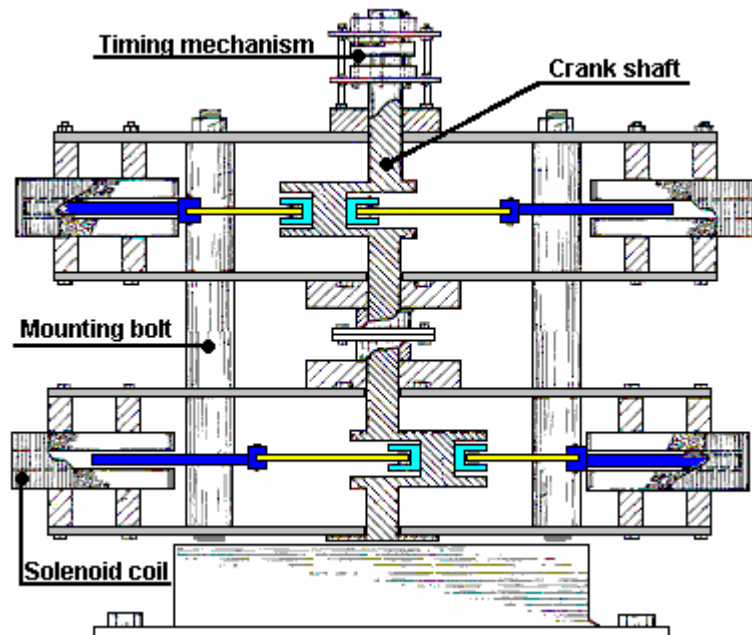

This style of motor looks very simple and its operation is indeed very simple, but it is surprising how powerful the resulting drive is, and it is a very definite contender for a serious free gravitic energy device in spite of its simplicity.

An alternative suitable drive system could be produced by using the same style of permanent magnet and electromagnet drive utilised by the Adams motor, where electromagnets positioned just clear of the edge of the rotor disc are pulsed to provide an impulse to the drive shaft, in the case shown below, every 30 degrees of shaft rotation.

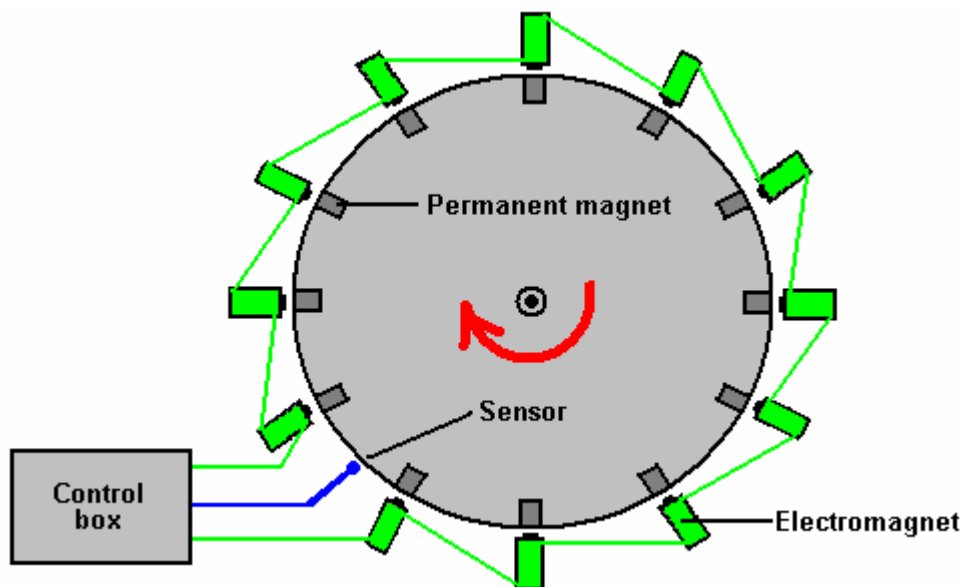

Here, the sensor generates a signal every time that one of the permanent magnets embedded in the rotor passes it. The control box circuitry allows adjustment of the time between the arrival of the sensor signal and the generation of a powerful drive pulse to the electromagnets, pushing the rotor onwards in its rotation. The control box can also provide control over the duration of the pulse as well, so that the operation can be fully controlled and tuned for optimum operation.

Any ordinary DC motor driven by a low-rate DC motor “speed controller” would also work in this situation, as it will generate a stream of impulses which are transmitted to the flywheel. The shaft of the flywheel will, of course, be coupled to an automotive alternator for generation of a low voltage output, or alternatively a mains voltage generator. It should be stressed that having several flywheels as part of the drive gearing, as Chas Campbell does, is a particularly efficient way of leading-out excess gravitational energy. Part of the electrical output can be used to provide a stabilised power supply to operate the drive for the flywheel.

It is possible to make the Chas Campbell arrangement into a more compact construction by reducing the size of the flywheel and introducing more than one flywheel into the design. It is perfectly possible to have more than one flywheel on a single axle shaft. The construction of the flywheels can be efficient if a central steel disc is used and two cast lead collars are attached to the rim on both sides of the web disc. This produces a flywheel which is as cheap and effective as can conveniently be made.

Although it is not shown on the diagram shown above, Chas does use additional discs. These are not particularly heavy, but they will have some flywheel effect. Ideally, these discs should be beefed up and given considerable weight so that they contribute substantially to the overall power gain of the device. This is what Chas’ present build looks like:

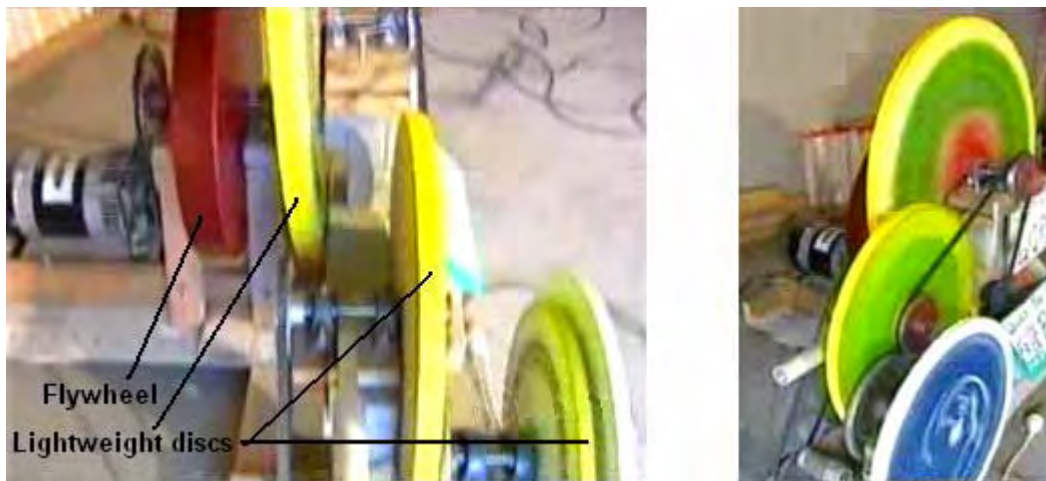

A possible alternative construction might be:

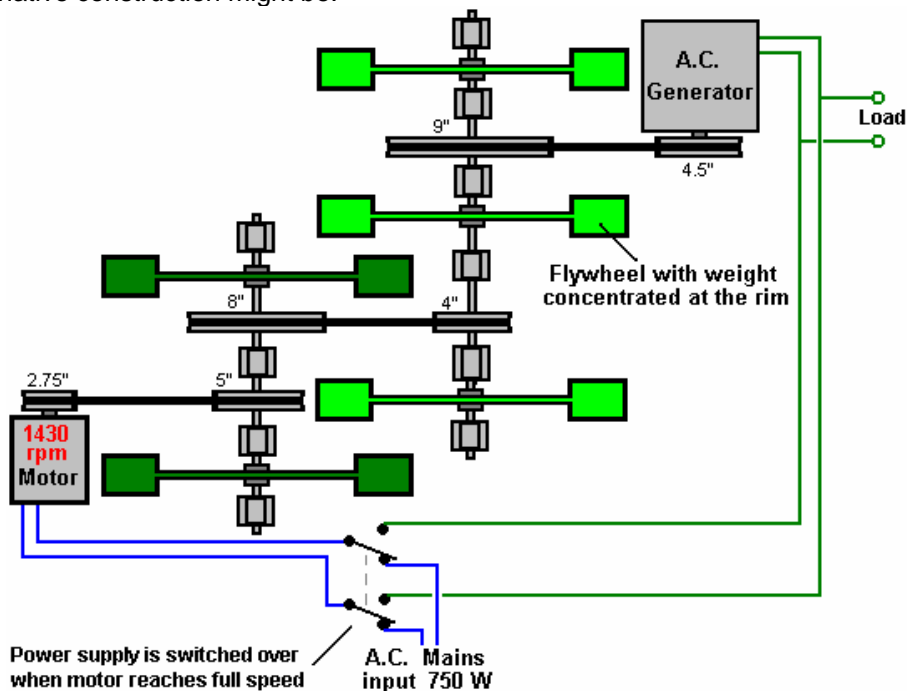

Here, there are five heavy flywheels mounted on two heavily supported strong axes, and while the two shown in dark green are only rotating at half the speed of the other three, the energy gain will be equal for each flywheel as each receives the same train of drive pulses. However, the pulley sizes might be better



chosen in accordance with Jacob's observations mentioned below.

The drive impulses can be from a DC motor fed with electrical pulses, perhaps via a standard "DC motor speed controller" or using electrical pulses to drive a series of permanent magnets spaced out around the edge of a circular rotor. In this instance, the electrical generation can be via a standard commercial generator, or it can be produced by using the electromagnet driving coils alternately to drive and to capture electrical energy. The following sketch shows a possible arrangement for this concept:

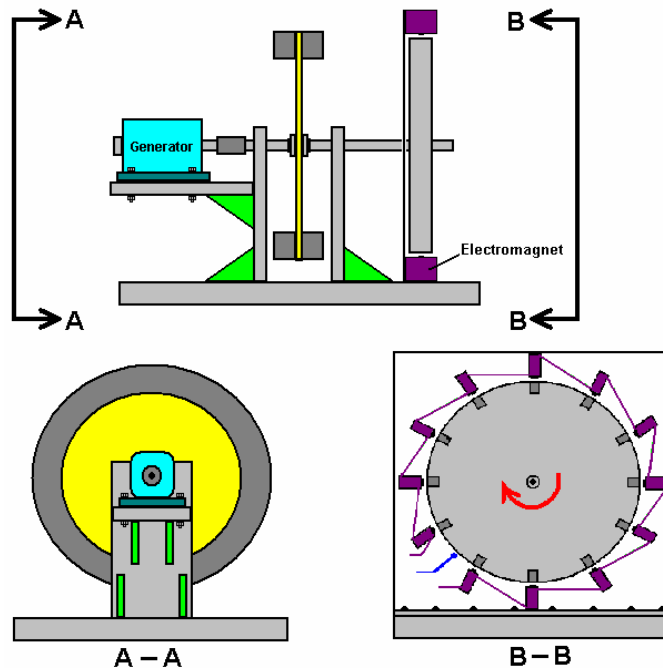

**Jacob Byzehr's Analysis.**

In 1998, Jacob lodged a patent application for a design of the type shown by Chas Campbell. Jacob has analysed the operation and he draws attention to a key design factor:

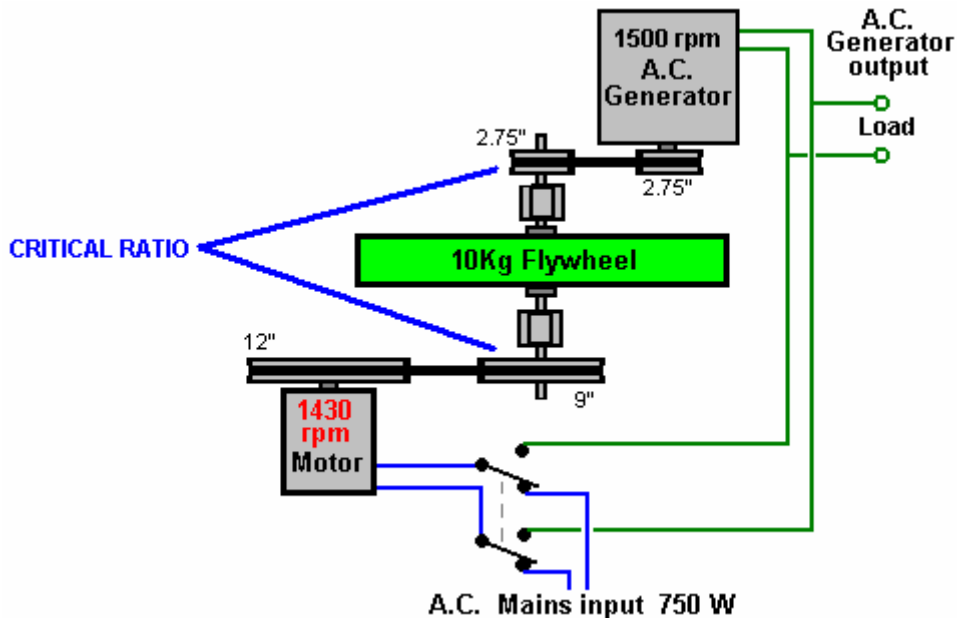

Jacob states that a very important feature for high performance with a system of this kind is the ratio of the diameters of the driving and take-off pulleys on the shaft which contains the flywheel, especially with systems where the flywheel rotates at high speed. The driving pulley needs to be three or four times larger than the power take-off pulley. Using Chas' 1430 rpm motor and a commonly available 1500 rpm generator, the 12:9 step-up to the shaft of the flywheel gives a satisfactory generator speed while providing a 3.27 ratio

between the 9-inch diameter driving pulley and the 2.75" diameter power take-off pulley. If a generator which has been designed for wind-generator use and which has its peak output power at just 600 rpm is used, then an even better pulley diameter ratio can be achieved.

### The Wilson Self-Powered DC Generator

Mr. Wilson of Texas built a self-powered generator system using an old table and some car parts. His construction was shaky, but in spite of that, it powered itself and other equipment. The table which he used was five feet (1.5 m) in diameter and 2-inches (50 mm) thick which means that it will have weighed at least 130 pounds or 60 Kilograms which is a substantial amount, well in excess of that used by Chas Campbell with his AC self-powered system. In this DC construction the system was driven by a standard, unmodified, off-the-shelf DC motor powered by two car batteries wired in parallel to give a larger current capacity. These batteries were kept charged up by two 'generators' from pre-1964 American cars (the closest available today are permanent magnet alternators). These generators also powered additional equipment and Mr Wilson pointed out that three or more generators could be run by the system, giving a substantial level of excess electrical power.

The machine has to be described as 'shaky' because he chose to convert the table top into a V-pulley belt drive flywheel by driving a series of nails into the edge of the wooden disc, with those nails angled to form a V shaped gap through which he ran a pulley belt. After three days of continuous running, those nails started to come out, causing him to power the system down. This unit was built around 1990, and if anyone decides to attempt a replication, then I suggest that the rim of the wooden disc is grooved to take the belt rather than relying on nails. The arrangement was like this:

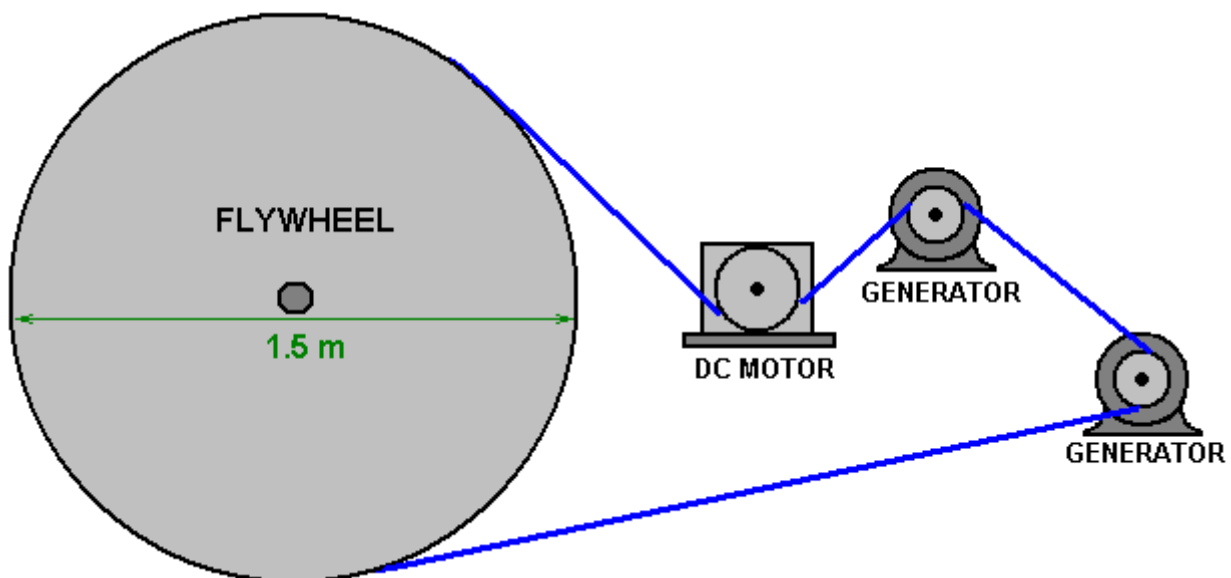

There was also a belt-tensioning roller which is not shown in the diagram above which assumes that the flywheel has been grooved to take the drive belt. Schematically, the arrangement was like this:

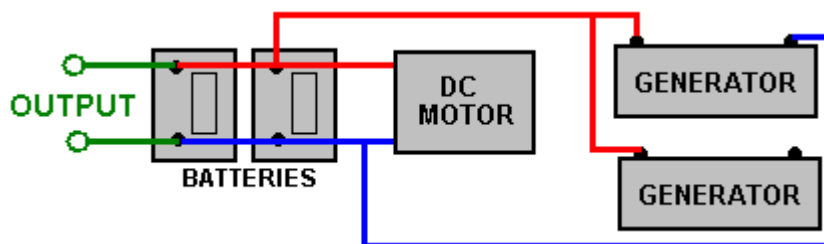

Here, the additional output can be used directly for powering 12-volt equipment or an inverter can be used to provide mains voltage and frequency. A typical inverter looks like this:



The battery power is connected to one end using thick cables to carry the heavy current, and one or more mains sockets are provided at the other end of the case, along with an On/Off switch and power indicators. Inverters come in many sizes and power ratings, generally ranging from 150 watts to 3,000 watts (3 kW). The more expensive ones are specified as "True Sine-Wave Output" but very few present day items of equipment will not run well on the cheaper versions which do not produce a true sine-wave output.

Mr Wilson decided not to patent his design and instead wanted it to be open-source information for anybody to use freely. However, the Jesse McQueen patent shown in chapter 13 looks to be Mr Wilson's design although the flywheel does not appear to be mentioned there. It should be stressed that the generator output needs to be high and so permanent magnet types are considered to be essential for this application. The specialised motor (and consequently, generator) winding methods of 'UFOpolitics' shown in chapter 2, raise efficiencies by a factor of typically 300% or more, and so would raise the output of this system very substantially if they were applied to the motor, or the generators, or both.

### John Bedini's COP=8 Pulsed Flywheel.

The Chas Campbell system is not an isolated case. On page 19 of the book "Free Energy Generation - Circuits and Schematics" John Bedini shows a diagram of a motor/generator which he has had running for three years continuously while keeping it's own battery fully charged.

At John's web site <http://www.icehouse.net/john1/index11.html> about half way down the page, there is a black and white picture of a very large construction version of this motor. The important thing about this motor is that it is being driven by electrical pulses which apply a continuous stream of short drive pulses to the flywheel. This extracts a steady stream of continuous energy drawn out from the gravitational field, enough to charge the driving battery and keep the motor running. The large version built by Jim Watson had an excess power output of many kilowatts, due to the very large size and weight of it's flywheel.

The overall strategy for this is shown here:

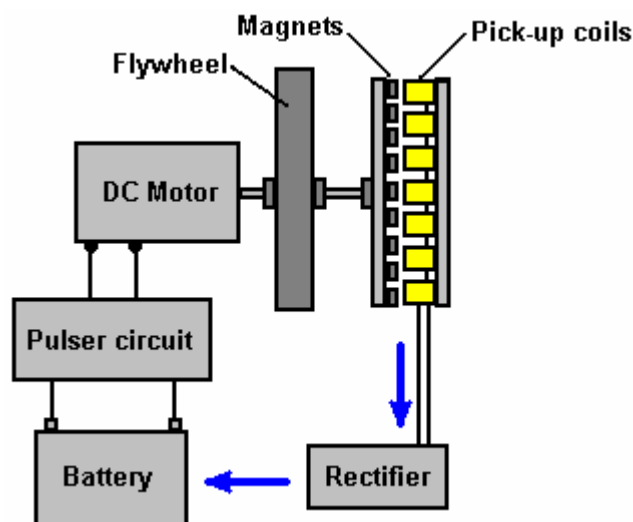

It is also likely that Joseph Newman's motor gains additional energy from its large physical weight of some 90 kilograms driven by a continuous stream of pulses. Any wheel or rotor assembly which is driven with a series of mechanical pulses, should benefit from having a serious flywheel attached to the shaft, or alternatively, the outer edge of the rotor. Engineers consider that effect of a flywheel on an irregular system is to iron out the irregularities in the rotation. That is correct as a flywheel does do that, but Lawrence Tseung's gravity "lead-out" theory indicates that those irregular pulses also add energy to the system.

With John's system, a capacitor is charged by the generator coils and then the drive circuit is effectively disconnected from the battery and the contents of the capacitor dumped into the battery. Then the capacitor link is effectively disconnected and the drive section connected again so that the process can be repeated indefinitely. While one flywheel is shown, there is no reason why more than one may not be used. Also, while only one set of magnets and pickup coils is shown, more can easily be added. The larger the system gets, the greater the available excess power becomes. An asymmetrically wound motor (chapter 2) should be considered when choosing a drive motor.

### **James Hardy's Self-Powered Water-Jet Generator.**

As described in more detail in Chapter 2 and Chapter 8, there is a very simple device based on a high-power water pump. In this system, a small quantity of water is pumped around continuously, in the same general style as an ornamental fountain. The difference here is that a high speed jet of water is produced and directed at a turbine wheel. The turbine wheel can be of any type as indicated in the patent which James has been awarded for this design. In the video at present on the web, the water wheel is of very simple design and yet works well – it is shown here:



Small discs are attached to the wheel at widely spaced intervals around its rim. The water jet hits these and applies an impulse to the wheel, driving it around, but also adding extra energy through those impulses.

The waterwheel is coupled to a standard electrical generator via pulleys and V-belts. The system is started using the mains supply and then when it is running at full speed, the electrical supply for the pump is switched over from the mains to the output of its own generator. This is exactly the same as Chas Campbell does with his pulsed flywheel and both systems are capable of powering additional standard electrical equipment intended for mains use.

Chas Campbell's flywheel, John Bedini's flywheel and this water-jet generator all demonstrate very clearly that environmental energy is readily available for us to use any time we choose to do so. All that is necessary is for us to construct one of these devices.

### **The Permanent Magnet Pendulum.**

At the present time, there is a short video clip on YouTube, showing a pendulum which has been running unaided for two years: <http://www.youtube.com/watch?v=SZjNbjhxgt4> and which uses both gravity and magnetism to keep going. The device is installed in a case with transparent sides:



The pendulum itself looks rather like a sledgehammer due to its rigid shaft and the additional magnets mounted on the weight. The above picture shows the pendulum at the end of its swing to the right and the picture below, in its extreme left hand swing position:



Which indicates the swing covers a fairly short distance. Mounted near the top of the pendulum, there are two pivoted arms which look quite like microphones, due to having large magnets mounted on their innermost ends:

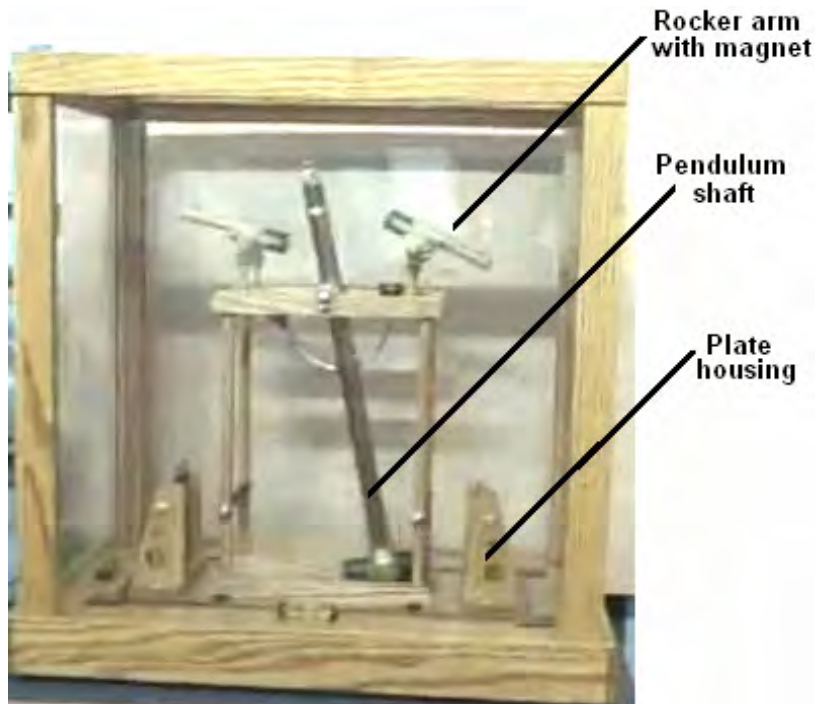

The device operates like this: The pendulum swings to the right and as it does so, it raises a magnet attached to the pendulum shaft by a curved silver arm:



Presumably, the arm is curved to avoid the constructional complications at the pendulum pivot which would be caused by a straight mounting arm attached to the pendulum shaft. The rising magnet attached to the pendulum pushes the magnet end of the rocker arm upwards even though it does not come close to it.

The rocker arm is used to raise and lower a plate which has a magnet mounted in it. The raising and lowering is achieved by having two cords attached to the end of the rocker arm and their other ends attached to the two upper corners of the moving plate:



The plate slides in two slots in the support housing and the plate movement is relatively small:



The tipping up of the lever arm drops the plate down as the pendulum approaches the plate. This introduces a magnetic braking effect where some of the momentum of the pendulum weight is stored in the opposing magnetic fields of the pendulum magnets and the plate magnet. This brakes the pendulum movement and gives it a magnetic push on its opposite swing, sustaining it's swinging day after day after day.

This is a clever arrangement and the device on display has been built to a very high standard of construction. It does not appear to have any additional energy take off, but seems quite likely that air-core coils could be used along the swing path to generate electrical power. The arrangement appears so close to John Bedini's pendulum battery charger that it may well be possible to use a pendulum of this type to charge batteries just as John does.

While this looks like a very simple device, it is highly likely that it requires exact adjustment of the length of the lever arms, the magnetic gap sizes in relation to the strength of the magnets, etc. etc. Repeated small adjustments are probably needed to get the device operating smoothly and sustaining the pendulum swing. All in all though, it is a very interesting device.

**Jerzy Zbikowski's Mechanical Power Amplifier.**

We come now to a device which I would love to describe as "impossible" but reluctantly, I can't actually do that. On the surface, this device has every appearance of being impossible, and yet it has been measured in a laboratory as being 147% efficient. Perhaps the laboratory measurements are wrong, however, there seems to be very little scope for measurement error as the device is so basically simple. My problem is that if the results are 100% genuine, which is distinctly possible, then a series of these arranged in a circle, each driving the next one, it would create a self-powered device and I can't explain where the driving power would come from. I can understand pretty much every other device in this eBook, but this one has me stumped. As I don't have any basis for claiming to be a genius, I am sharing the information here and I will let you decide if it can work as the patent claims that it does.

The patent in question is the very innocent looking US 7,780,559 entitled "Chain Transmission" which innocently states that it is a single-chain system for rotating a large gearwheel at the same rate as a smaller, driving gearwheel, and without question, that is exactly what it does. At this point, my Engineering training jumps in and says "sure, but the overall mechanical efficiency will be less than 100% and while the larger gearwheel does rotate at the same rate, it will do so far less powerfully, and you have exactly the same effect as driving the second shaft with a small gearwheel which has a large gearwheel bolted to it.

The only problem with this is that testing appears to show that this is not the case and in fact, (probably due to the larger lever arm of the larger gearwheel radius) the arrangement has an output power which was measured in the prototype as being 47% greater than the input power. OK, so how does it work?

In the diagram shown here, a small-diameter driving wheel marked "1" has exactly the same number of teeth as the much larger driven wheel marked "2". As they are linked by a chain, these two wheels rotate at exactly the same rate, that is, the revolutions per minute are exactly the same for each of those two wheels.

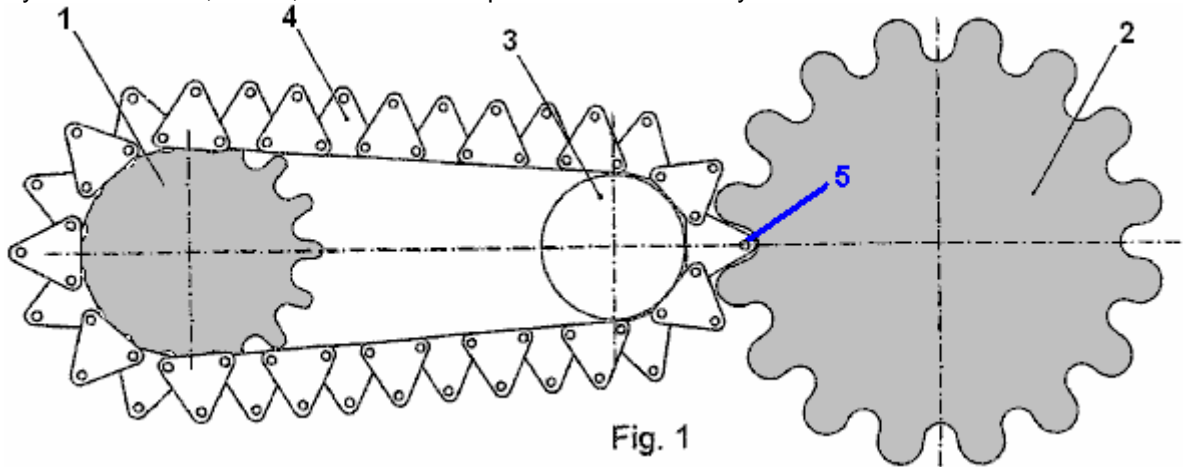

The way that the chain manages to push the larger teeth of the large wheel is by having the driving roller "5" raised by a triangular link "4" so that it has the same rotational pitch as the teeth on the larger wheel.

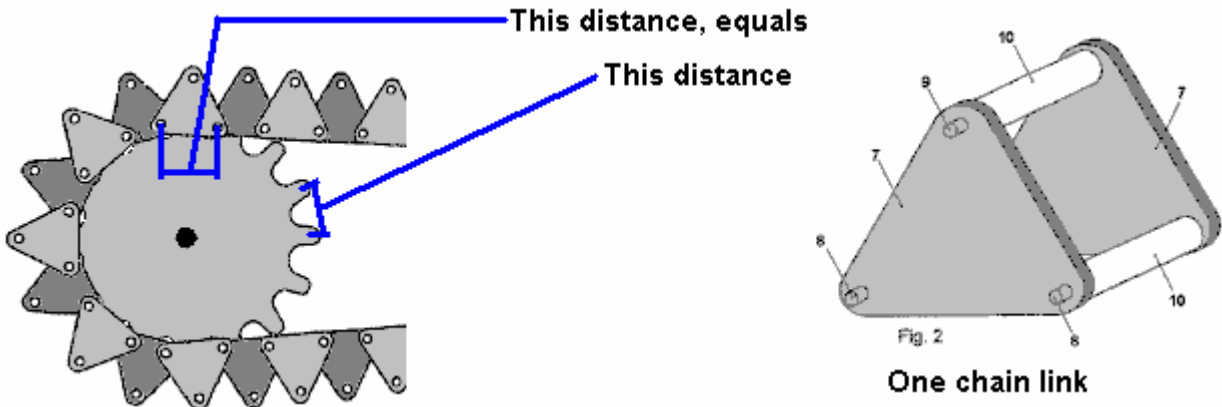

My immediate reaction to this is to say that as the triangular links in the drive chain have a somewhat narrower base than their height, that this will cause the driving roller "5" to have a less powerful drive than



the driving wheel “1”. But if the lab measurements made on the prototype are correct, then that increased level arm effect is not sufficient to overcome the gains caused by the increased radius of the larger wheel. The lab measurements were made at the certified laboratory of the Institute of Electrical Machines and Drives of the Technical University of Wrocław, Poland. A video presentation in Polish can be seen at <http://www.focus.pl/video/film/perpetuum-mobile/>. It is difficult to see how this chain drive could be COP>1 but it has the advantage that anyone with good mechanical construction skills can test it without the need for any knowledge of electronics.

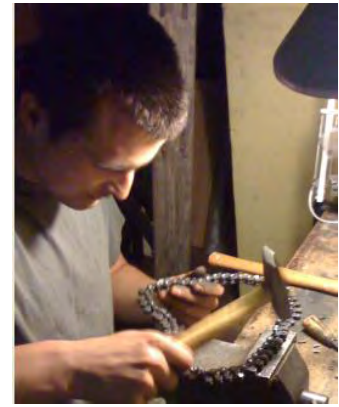

### Gravitational Effects.

We are all familiar with the effects of gravity. If you drop something, it falls downwards. Engineers and scientists are usually of the opinion that useful work cannot be performed on a continuous basis from gravity, as, they point out, when a weight falls and converts its “potential energy” into useful work, you then have to put in just as much work to raise the weight up again to its starting point. While this appears to be a sound analysis of the situation, it is not actually true.

Some people claim that a gravity-powered device is impossible because, they say that it would be a “perpetual motion” machine, and they say, perpetual motion is impossible. In actual fact, perpetual motion is not impossible as the argument on it being impossible is based on calculations which assume that the object in question is part of a “closed” system, while in reality, it is most unlikely that any system in the universe is actually a “closed” system, since everything is immersed in a massive sea of energy called the “zero-point energy field”. But that aside, let us examine the actual situation.

Johann Bessler made a fully working gravity wheel in 1712. A 300 pound (136 Kg) wheel which he demonstrated lifting a 70 pound weight through a distance of 80 feet, demonstrating an excess power of 5,600 foot-pounds. Considering the low level of technology at that time, there would appear to be very little scope for that demonstration to be a fake. If it were a fake, then the fake itself would have been a most impressive achievement.

However, Bessler acted in the same way as most inventors, and demanded that somebody would have to pay him a very large amount of money for the secret of how his gravity wheel worked. In common with the present day, there were no takers and Bessler took the details of his design to the grave with him. Not exactly an ideal situation for the rest of us.

However, the main argument against the possibility of a working gravity wheel is the idea that as gravity appears to exert a direct force in the direction of the earth, it therefore cannot be used to perform any useful work, especially since the efficiency of any device will be less than 100%.

While it is certainly agreed that the efficiency of any wheel will be less than 100% as friction will definitely be a factor, it does not necessarily follow that a successful gravity wheel cannot be constructed. Let us apply a little common sense to the problem and see what results.

If we have a see-saw arrangement, where the device is exactly balanced, with the same length of a strong plank on each side of the pivot point, like this:

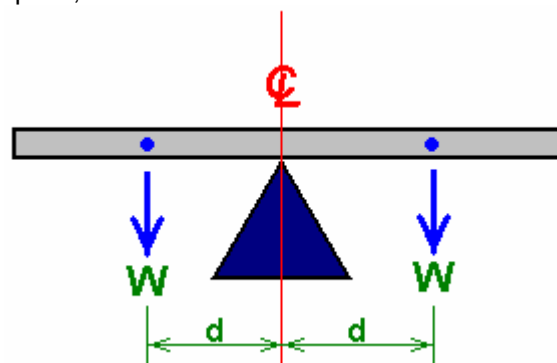

It balances because the weight of the plank (“W”) to the left of the support point tries to make the plank tip over in a counter-clockwise direction, while exactly the same weight (“W”) tries to tip it over in a clockwise direction. Both turning forces are d times W and as they match exactly, the plank does not move.

The turning force ( $d$  times  $W$ ) is called the “torque”, and if we alter the arrangement by placing unequal weights on the plank, then the beam will tip over in the direction of the heavier side:

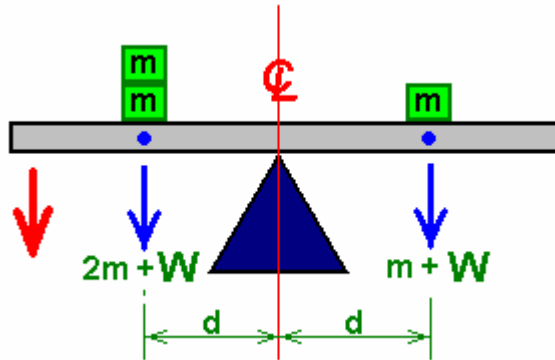

With this unequal loading, the beam will tip down on the left hand side, as indicated by the red arrow. This seems like a very simple thing, but it is a very important fact. Let me point out what happens here. As soon as the weight on one side of the pivot is bigger than the weight on the other side (both weights being an equal distance from the pivot point), then the heavy plank starts to move. Why does it move? Because gravity is pushing the weights downwards.

One other point is that the distance from the pivot point is also important. If the added weights “ $m$ ” are equal but placed at different distances from the pivot point, then the plank will also tip over:

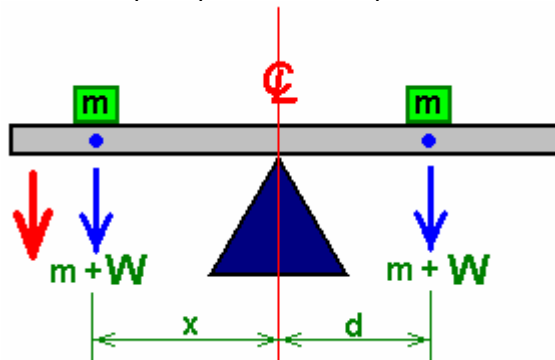

This is because the larger lever arm “ $x$ ” makes the left hand weight “ $m$ ” have more influence than the identical weight “ $m$ ” on the right hand side.

Do you feel that these facts are just too simple for anyone to really bother with? Well, they form the basis of devices which can provide real power to do real work, with no need for electronics or batteries.

The following suggestions for practical systems are put forward for you to consider, and if you are interested enough test out. However, if you decide to attempt to build anything shown here, please understand that you do so entirely at your own risk. In simple terms, if you drop a heavy weight on your toe, while other people may well be sympathetic, nobody else is liable or responsible for your injury - you need to be more careful in the future ! Let me stress it again, this document is for information purposes only.



### The Deflected-Weight Generator of Mikhail Dmitriev.

Mikhail is a Russian experimenter who has worked for many years developing and testing gravity-powered devices. His persistence has paid off and he has been very successful. His work is shown on Sterling Allan’s web site [http://peswiki.com/index.php/Directory:Mikhail\\_Dmitriev\\_Gravity\\_Wheel](http://peswiki.com/index.php/Directory:Mikhail_Dmitriev_Gravity_Wheel) where there are videos and photographs of several of his prototypes. It is envisaged that large versions which generate 6 to 12 kilowatts of excess power will become available for purchase in 2011. Each of his various designs is

based on the principle of having weights attached to a wheel and arranging for those weights to be offset outwards when falling and offset inwards when rising. Because of the different lever arms involved, that gives a force imbalance which causes the wheel to rotate continuously and if the weights are of a considerable size, then the rotation is powerful and can be used to generate electrical energy.

In order to arrange for the weights to be offset as the wheel goes around, each weight is suspended on a pivoted arm:



For the device to operate as required, that suspension arm needs to be moved to (say) the right when falling and be centred or deflected to the right when rising. Mikhail has chosen to use a small amount of electrical power to make this happen, because the energy provided by gravity in turning the wheel far outweighs the small electrical input needed to make the wheel rotate.

Several mechanisms for making this happen have been tested as you can see from Sterling's presentation. One method is to push the lever arms to the right with a simple rotating disc which has deflector arms attached to it:



After being given the sideways push, each weight stays off centre until it reaches the bottom of its travel. Please remember that while the weights show here are tiny, a full-size working device will have weights which weigh a total of perhaps 130 kilograms and the forces involved are then large. The picture above is a little difficult to make out as the rotating disc is transparent and the support for the rotating arms is also transparent. The horizontal metal arm is there to support the transparent panel on which the 'arms wheel' bearing is mounted.

An alternative method is to use a small motor which drives the arms directly as shown here:

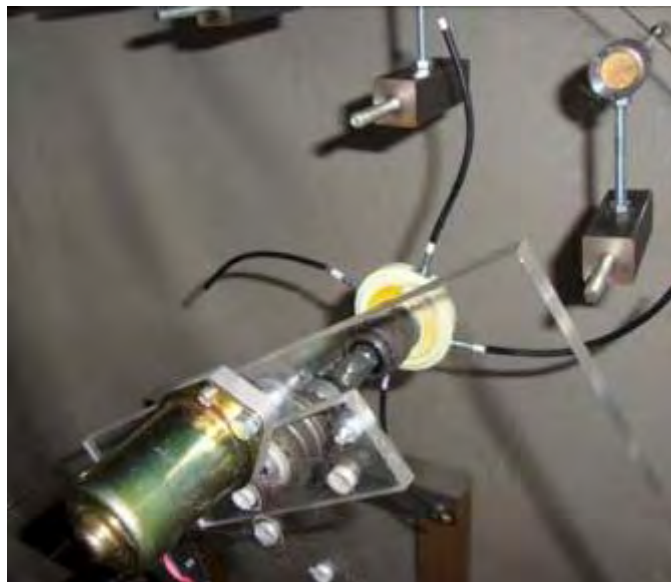

Each weight is held rigidly and so when the motor arm presses against it, the lever arm is pushed out sideways without the weight twisting away from the motor arm. These prototype weights are not heavy, but when a working unit is being built they will have considerable weight, so to get a well balanced arrangement, it might be advisable to have weights on both sides of the wheel so that there is no offset axial load placed on the shaft which supports the wheel:

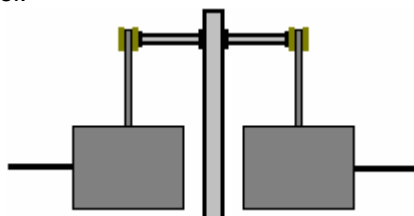

Mikhail's arrangement works well when it relies on the swinging movement of the weights to keep them off centre during the time when they are falling and you can watch a video of that happening. However, it makes one wonder if it would not be possible to arrange for this movement without the need for a motor, although using a motor is a very clever and sensible method of ensuring rotational power. Perhaps if two stationary deflectors were used, one to keep the weights out to the right when falling and one to keep them out to the right when rising, a viable system might be created. Perhaps something like this:

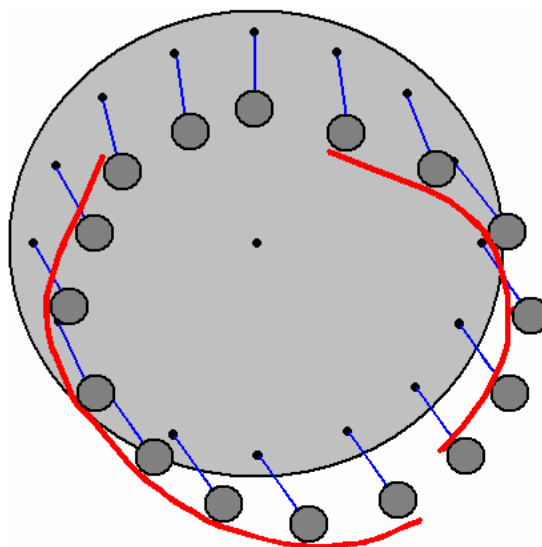

Admittedly, the deflector pieces would have a smoother shape than drawn here, but the principle is shown in spite of the poor quality of the diagram. Where heavy weights are involved, each could have a roller bearing pressing between the weight and the deflector shield in order to minimise friction as the weight slides past. Alternatively, the deflector shield could be faced with powerful magnets opposing similar magnets attached

to the weights which would give a no-contact, very low friction movement. A fairly similar idea is part of the next entry from Dale Simpson.



### Dale Simpson's Gravity Wheel Suggestion.

The design of gravity-operated machines is an area which has been of considerable interest to a number of people for quite some time now. The design shown here comes from Dale Simpson of the USA. It should be stressed that the following information is published as open-source, gifted to the world and so it cannot be patented by any individual or organisation. Dale's prototype wheel has a diameter of about five feet, utilising weights of a substantial value. The overall strategy is to create excess torque by having the weights slide along metal rods radiating from a central hub somewhat like the spokes of a cart wheel. The objective is to create an asymmetrical situation where the weights are closer to the hub when rising, than they are when falling.

The difficulty with designing a system of this type is to devise a successful and practical mechanism for moving the weights in towards the hub when they are near the lowest point in their elliptical path of movement. Dale's design uses a spring and a latch to assist control the movement of each weight. The key to any mechanical system of this type is the careful choice of components and the precise adjustment of the final mechanism to ensure that operation is exactly as intended. This is a common problem with many free-energy devices as careless replication attempts frequently result in failure, not because the design is at fault, but because the necessary level of skill and care in construction were not met by the person attempting the replication. Here is a sketch of Dale's design:

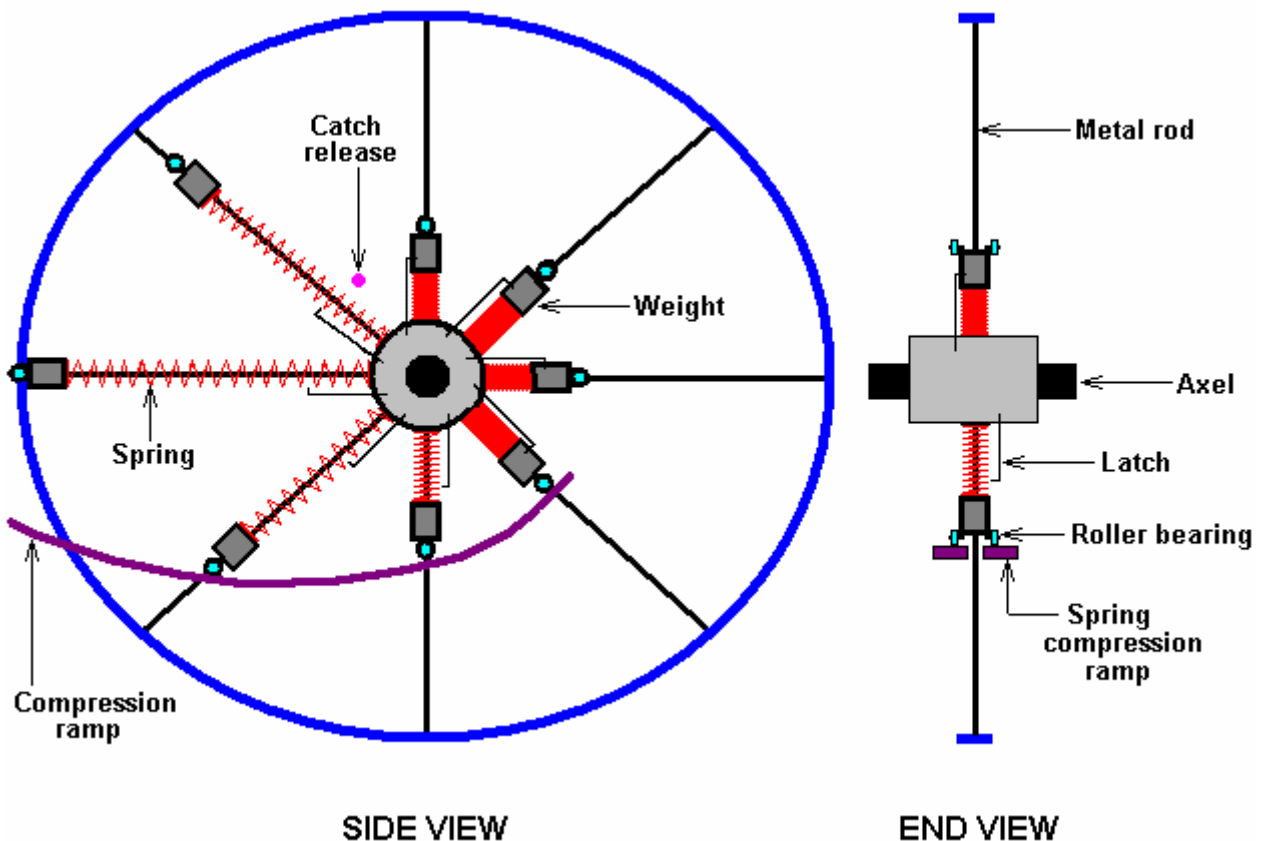

The wheel has an outer rim shown in blue and a central hub shown in grey. Metal spokes run out radially from the hub to the rim. Eight spokes are shown in this diagram as that number allows greater clarity, but a larger number would probably be beneficial when constructing a wheel of this type.

The wheel as shown, rotates in a counter-clockwise direction. Each weight, shown in dark grey, has a pair of low-friction roller bearings attached to it. There is also a spring, shown in red, between the weight and the hub. When a weight reaches the 8-o'clock position, the roller bearings contact a spring compression ramp, shown in purple. This ramp is formed of two parts, one on each side of the spokes, providing a rolling ramp for each of the two roller bearings. The ramp is formed in a curve which has a constant rate of approach towards the hub of the wheel.

The ramp is positioned so that the spring is fully compressed when the weight has just passed the lowest point in its travel. When the spring is fully compressed, a latch holds it in that position. This holds the weight in close to the hub during its upward movement. The springs are not particularly powerful, and should be just strong enough to be able to push the weight back towards the rim of the wheel when the spoke is at forty five degrees above the horizontal. The "centrifugal force" caused by the rotation assists the spring move the weight outwards at this point. The push from the spring is initiated by the latch being tripped open by the latch release component shown in pink.

The weights have an inward motion towards the hub when they are pushed by the wheel's turning motion which forces the roller bearings upwards along the spring-compression ramp. They have an outward motion along the spokes when the catch holding the spring compressed is released at about the 11-o'clock position. The latch and the release mechanism are both mechanical - no electronics or electrical power supply is needed in this design.

These details are shown in the diagram below:

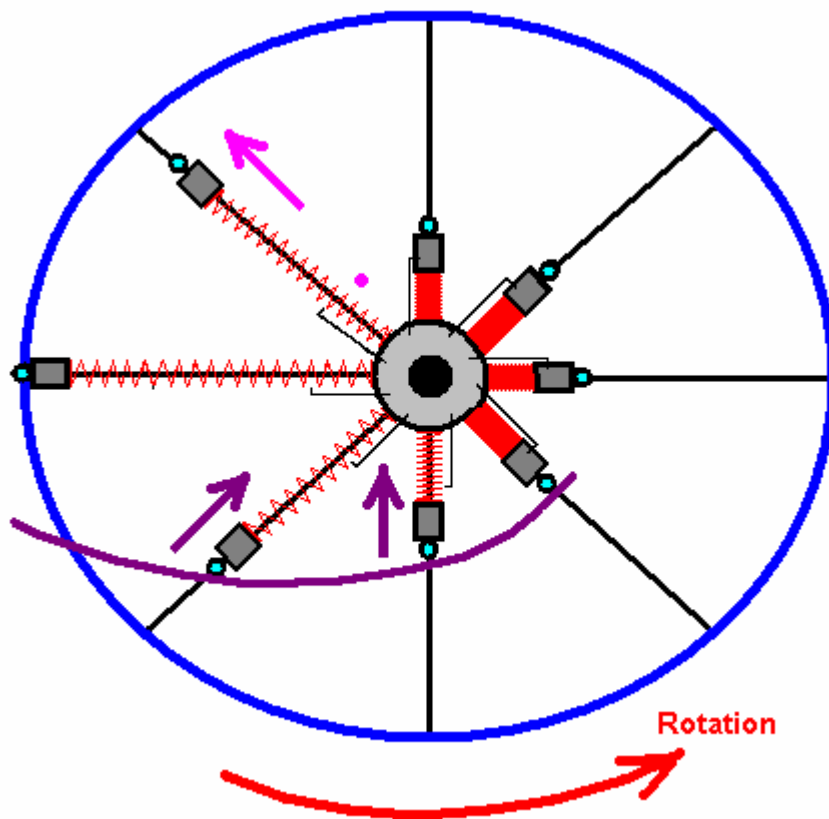

The question, of course is, will there be enough excess power to make the wheel rotate properly? The quality of construction is definitely a factor as things like the friction between the weights and their spokes needs to be very low. Let us consider the forces involved here:

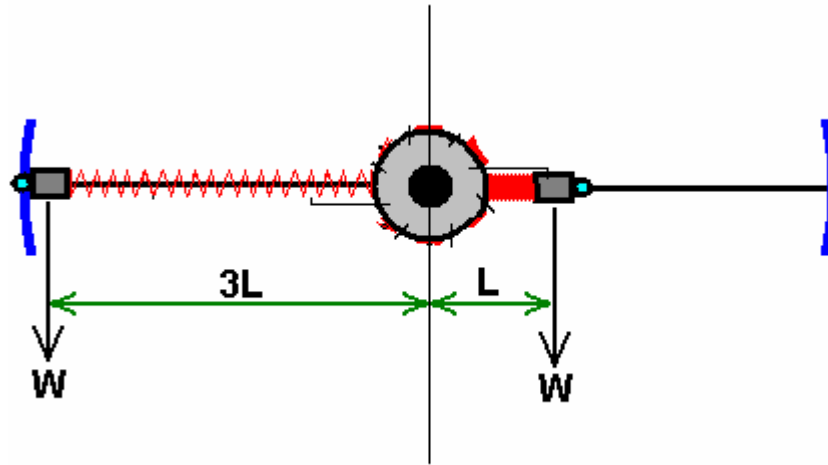

Take any one weight for this calculation. Any excess rotational energy will be created by the difference between the forces attempting to turn the wheel in a clockwise direction and those forces trying to turn the wheel in a counter-clockwise direction. For the purpose of this discussion, let us assume that we have built the wheel so that the compressed-spring position is one third of the spring-uncompressed position.

As the weights are all of the same value "W", the see-saw turning effect in a clockwise direction is the weight ("W") multiplied by it's distance from the centre of the axle ("L"). That is,  $W \times L$ .

The turning effect in the counter clockwise direction is the weight ("W") multiplied by it's distance from the centre of the axle (" $3W$ "). That is,  $W \times 3 \times L$ .

So, with  $WL$  pushing it clockwise, and  $3WL$  pushing it counter-clockwise, there is a net force of  $(3WL - WL)$ , i.e. a net force of  $2WL$  driving the wheel in a counter-clockwise direction. If that force is able to push the weight in towards the hub, compressing the spring and operating the spring latch, then the wheel will be fully operational. There is actually, some additional turning power provided by the weights on the left hand side of the diagram, both above and below the horizontal, as they are a good deal further out from the axle than those with fully compressed and latched springs.

The only way of determining if this design will work correctly is to build one and test it. It would, of course, be possible to have several of these wheels mounted on a single axle shaft to increase the excess output power available from the drive shaft. This design idea has probably the lowest excess power level of all those in this document. The following designs are higher powered and not particularly difficult to construct.

### The Abdulsalam Al-Mayahi Gravity Wheel

This design for a gravity-operated wheel capable of generating electrical power on a continuous basis, comes from Abdulsalam Al-Mayahi, is of very simple construction and currently is the subject of a patent application. While it looks something similar to Dale Simpson's design shown above, they actually have very little in common. This design does not have springs or latches but instead, operates on a combination of momentum and gravitational forces.

The implementation of the design shown here, while simple in concept, uses fairly sophisticated mechanical parts. There is a good chance that if carefully built and well lubricated, that a relatively crude version built from scrap components found locally, could function perfectly well.

This design does not claim to self-start from a stationary position but is intended to be started manually, spinning it up to speed so that the inertial effects push the weights out to the rim of the wheel with the need to roll along the inner deflection rail. The set-up is like this:

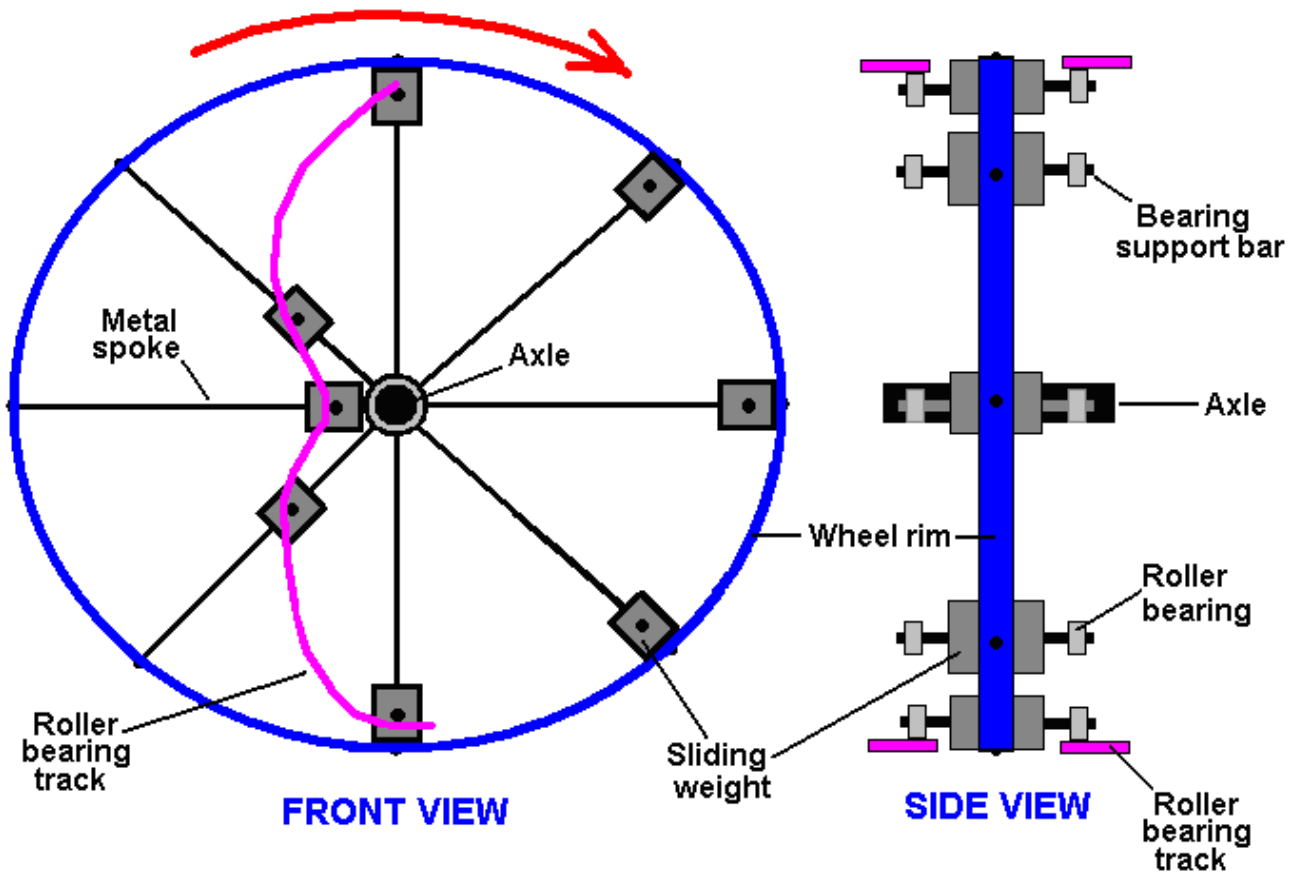

This gravity-powered motor has a metal rim (shown in blue in the diagram above) supported by a number of metal spokes which radiate outwards from the central axle hub which is of robust construction. On each spoke, there is a substantial sliding weight and each of these weights has a metal bar projecting outwards from its centre of gravity, supporting a roller bearing on each side of the weight.

The generator is initially spun by hand or by a starter motor. This causes the weights to be pressed outwards by the forces resulting from this rotation. Each weight would normally then be pressed against the metal rim as its circular path can only happen if there is a continuous inward acceleration towards the axle.

This normal situation is not allowed to occur as a stationary roller bearing track is installed. The roller bearing of each weight encounters this track or deflection rail, when it reaches the lowest point in its movement. The very start of the track is tangential to the bearing's movement so that there is no impact when the bearing first touches the track. As the wheel continues to rotate, the track forces the weight inwards towards the axle, much of the energy required to do this, coming from the momentum of the weight itself. The shape of the track is arranged so that the weight reaches the axle hub during a 90-degree rotation of the wheel. It is also shaped in such a way that the distance travelled up the spoke is constant for each degree of rotation. This ensures that the weight-sliding operation is smooth and continuous.

This forced movement causes the counter-clockwise rotational torque to be far less than the clockwise rotational torque because each weight in this "6 o'clock to 9 o'clock" sector is much closer to the axle than are the weights at the opposite side of the wheel in the "12 o'clock to 3 o'clock" sector.

The roller-bearing track continues through the "9 o'clock to 12 o'clock" sector, allowing each weight to gradually return to the rim of the wheel, but doing this without getting far away from the axle, thus adding further to the torque imbalance as each of the weights in the opposing "3 o'clock to 6 o'clock" sector are fully extended to the rim of the wheel and so are producing their maximum torque as the wheel rotates. This torque imbalance not only keeps the wheel rotating, but it also provides excess power for other applications such as spinning an electrical generator.



The power of the wheel can be increased by:

- (a) Increasing the mass of each weight, and/or
- (b) Increasing the diameter of the wheel, and/or
- (c) Mounting two or more wheels on the axle, (ideally, separated angularly in order to provide the smoothest operation possible).

To assist with getting the generator spinning, a second weight-deflection rail is introduced:

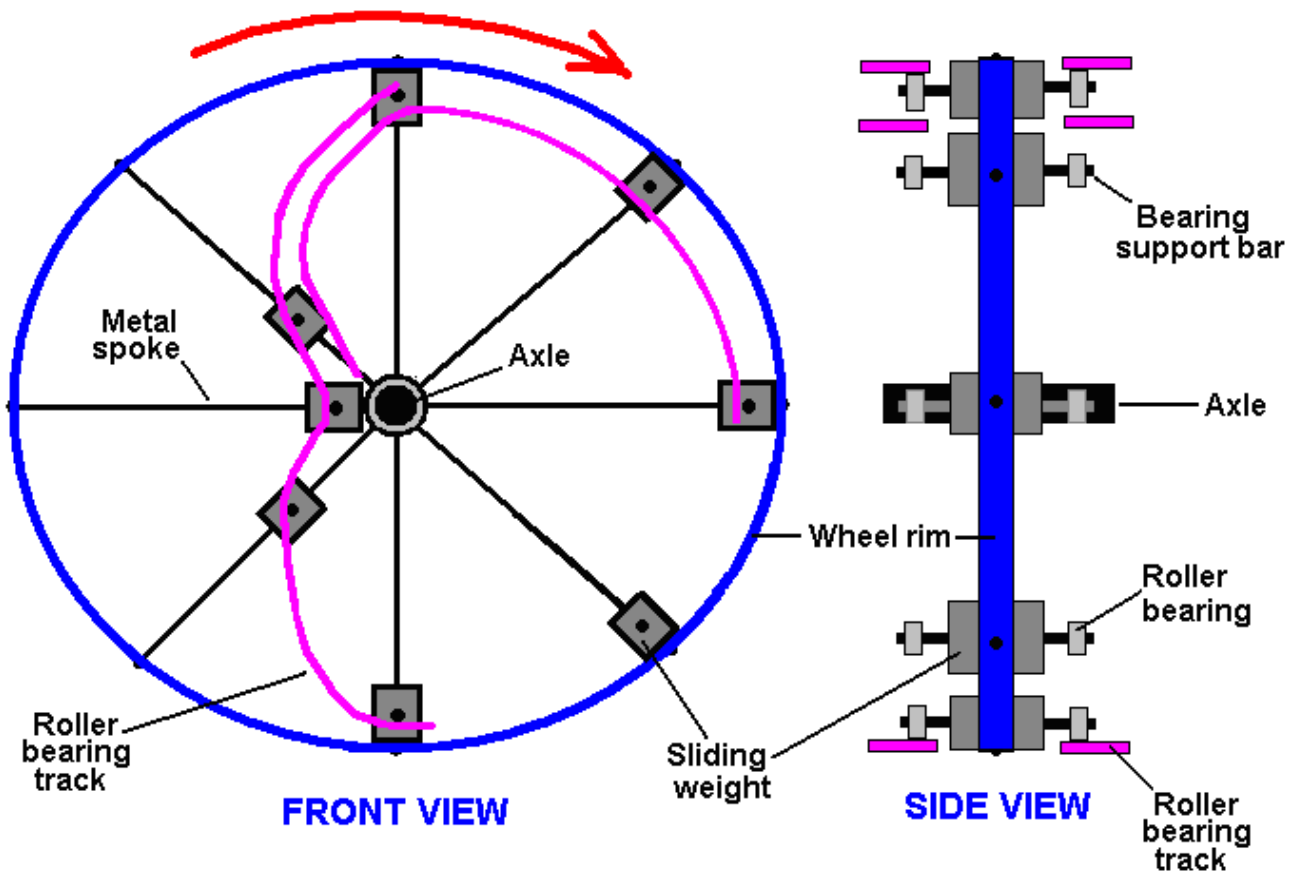

During normal, full-speed operation, this second track does not touch the roller bearings at all as each weight is pressed tightly against the rim of the wheel, but during the start-up process, this additional track ensures that the weights stay out near the rim in the critical “12 o’clock to 3 o’clock” sector and follow the desired path in the “9 o’clock to 12 o’clock” sector.

In the diagrams shown above, only one gravity-driven wheel is shown. While this is a perfectly viable arrangement, the output power can be increased by attaching additional wheels with their spokes and weights. As the wheels are located side by side, it is possible to use a single roller-bearing track to support the bearings on each side of it as shown here:

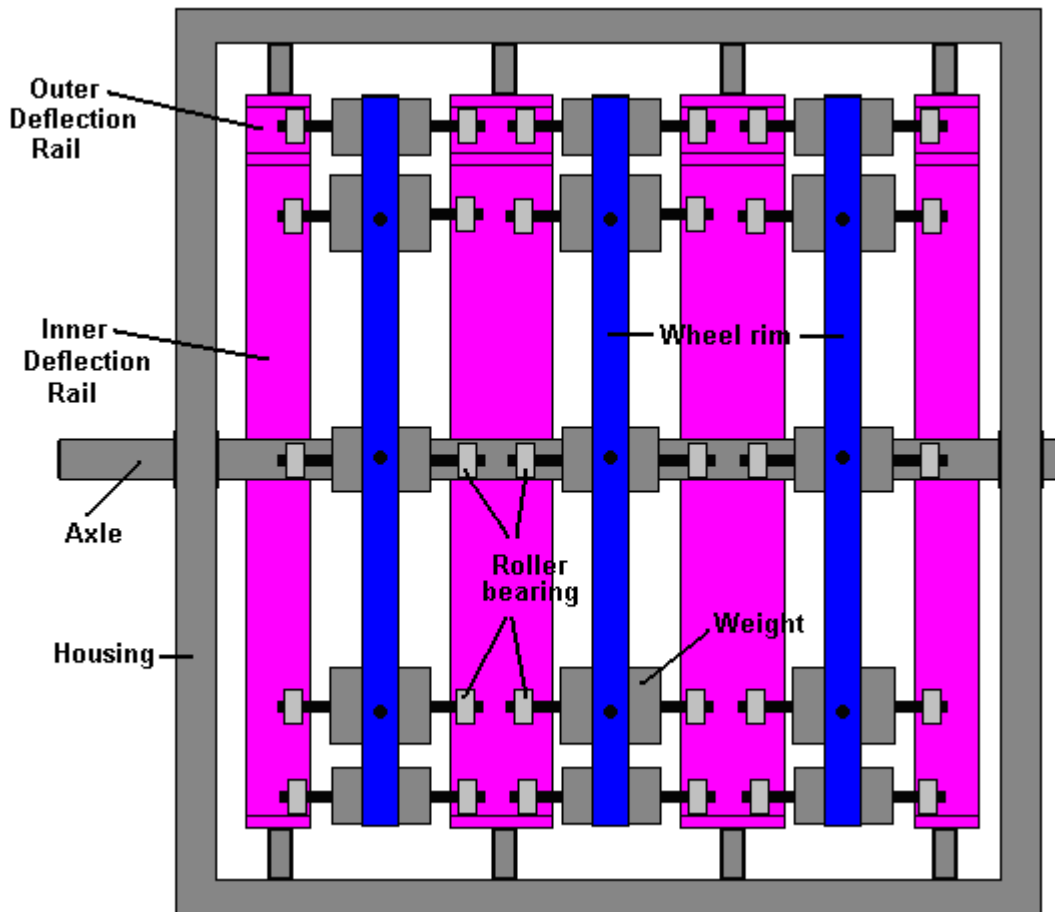

An important feature of this design is the minimising of friction between the weights and the rods which they slide along. This is particularly important at the “6 o'clock” to “9 o'clock” region where the weights have to alter direction rapidly and will press strongly against the spokes of the wheel when they are doing this. To minimise the friction encountered by the sliding weights, one effective option is to install a pair of roller bearings on all four sides of the spoke, eight bearings in all, embedded in each weight. To facilitate this, each weight can comprise four sections as shown here:

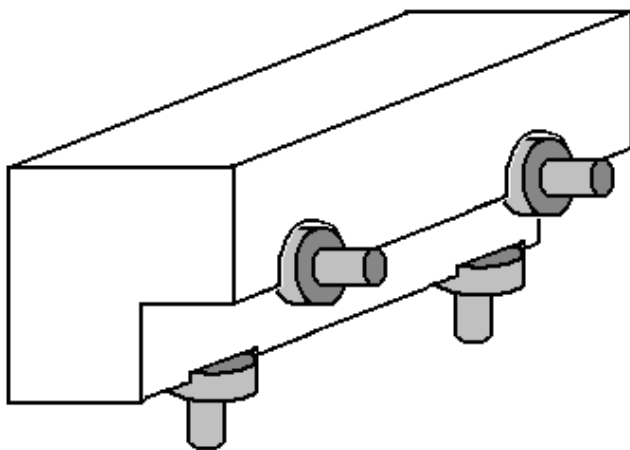

**PERSPECTIVE VIEW**

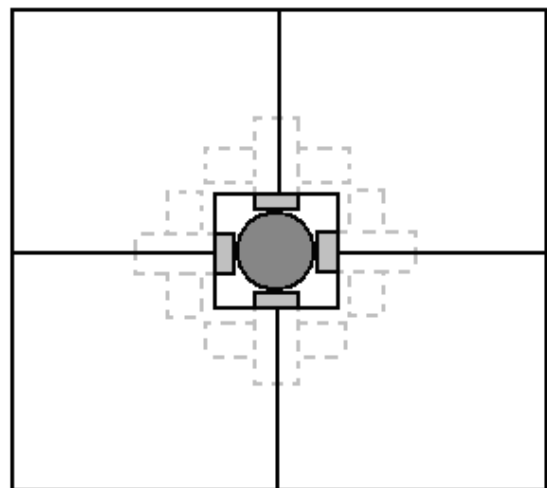

**END VIEW**

While the motion of the weight along the spoke has been described as “sliding”, the reality is that the weights roll along the spokes supported on four sides by the roller bearings. A piece of cushioning material is placed on the rim or on the weights in order to soften the impact when they come together.

### Veljko Milkovic's Pendulum/Lever System.

The concept that it is not possible to have excess power from a purely mechanical device is clearly wrong as has recently been shown by Veljko Milkovic at <http://www.veljkomilkovic.com/OscilacijeEng.html> where his two-stage pendulum/lever system shows a COP = 12 output of excess energy. COP stands for "Coefficient Of Performance" which is a quantity calculated by dividing the output power by the input power **which the operator has to provide** to make the system work. Please note that we are talking about power levels and not efficiency. It is not possible to have a system efficiency greater than 100% and it is almost impossible to achieve that 100% level.

Here is Veljko's diagram of his very successful lever / pendulum system:

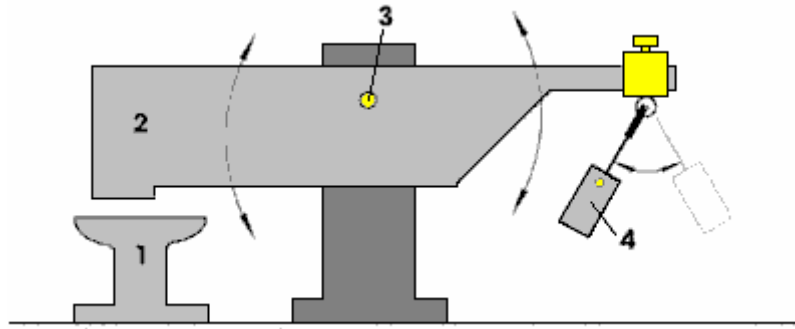

Here, the beam 2 is very much heavier than the pendulum weight 4. But, when the pendulum is set swinging by a slight push, the beam 2 pounds down on anvil 1 with considerable force, certainly much greater force than was needed to make the pendulum swing.

As there is excess energy, there appears to be no reason why it should not be made self-sustaining by feeding back some of the excess energy to maintain the movement. A very simple modification to do this could be:

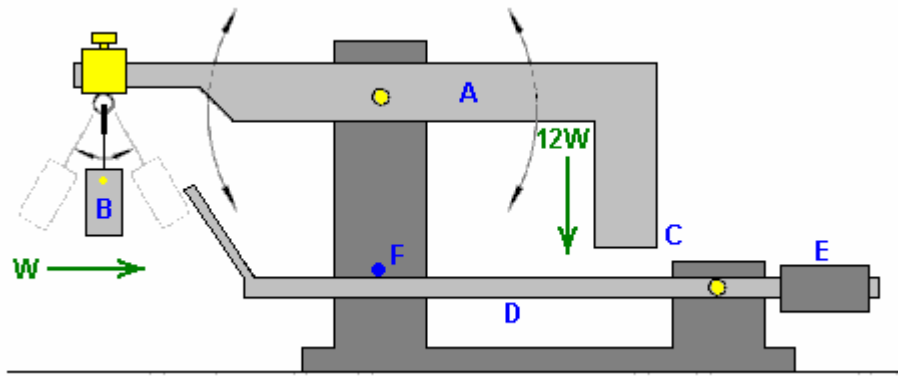

Here, the main beam A, is exactly balanced when weight B is hanging motionless in its "at-rest" position. When weight B is set swinging, it causes beam A to oscillate, providing much greater power at point C due to the much greater mass of beam A. If an additional, lightweight beam D is provided and counterbalanced by weight E, so that it has a very light upward pressure on its movement stop F, then the operation should be self-sustaining.

For this, the positions are adjusted so that when point C moves to its lowest point, it just nudges beam D slightly downwards. At this moment in time, weight B is at its closest to point C and about to start swinging away to the left again. Beam D being nudged downwards causes its tip to push weight B just enough to maintain its swinging. If weight B has a mass of "W" then point C of beam A has a downward thrust of  $12W$  on Veljko's working model. As the energy required to move beam D slightly is quite small, the majority of the  $12W$  thrust remains for doing additional useful work such as operating a pump.

**Amr Al-Hossary's Patent.**

If that is the case, then the design should perhaps be modified along the lines of the patent application of Amr Al-Hossary where the hinged plates are attached directly to the rotor. That way, the plate lever arm definitely comes into play:

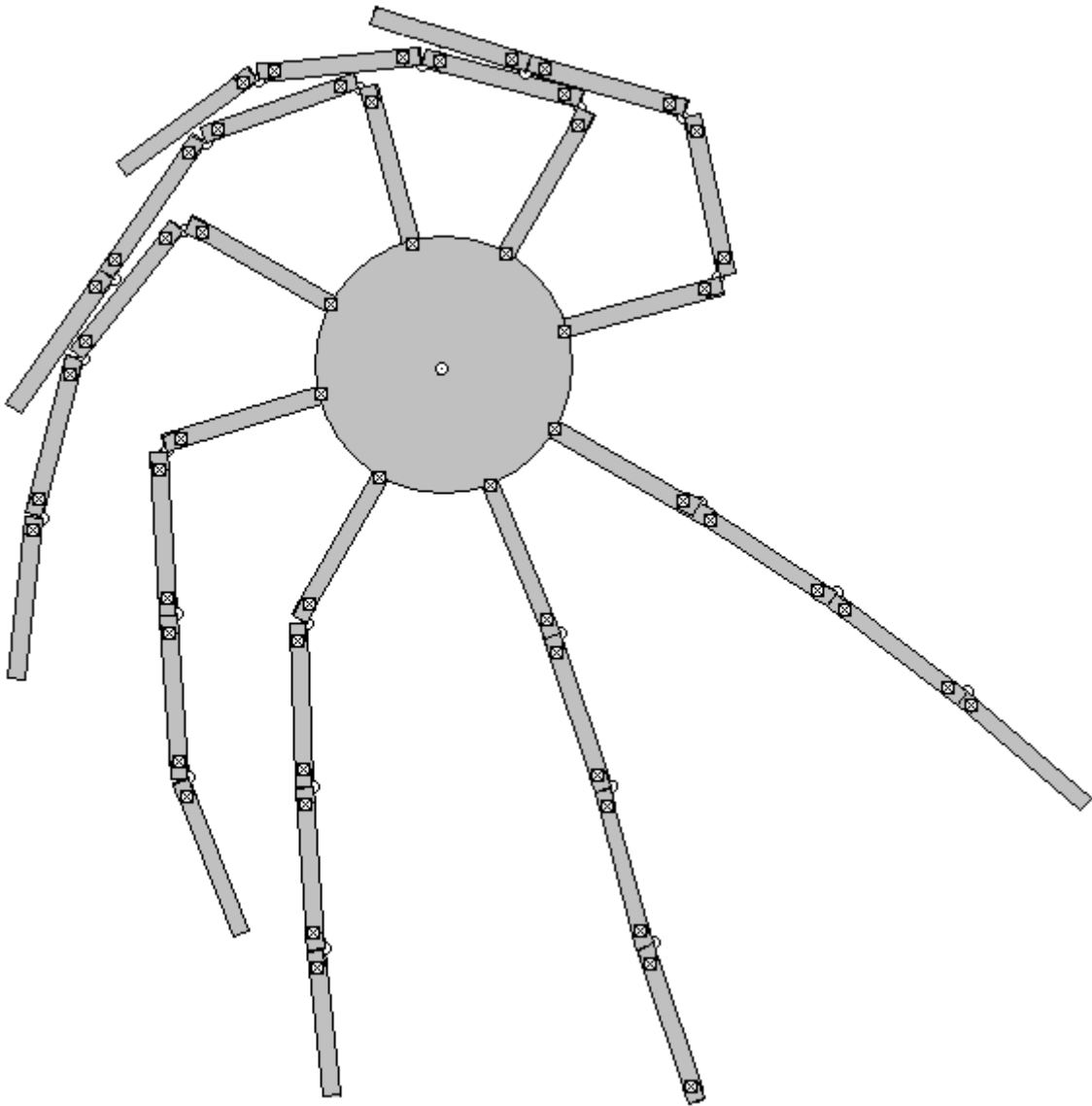

Here, the hinged arms or plates will also give an impact impulse when they open out to their full extent and that provides additional turning power. However, the imbalance between the two side is not a major amount and so this design is not likely to provide a large amount of torque for driving external loads.

**Murilo Luciano's Gravity Chain Suggestion.**

Murilo Luciano of Brazil, has devised a very clever, gravity-operated power device which he has named the "Avalanche-drive". Again, this design cannot be patented as Murilo has gifted it to the world as a royalty-free design which anybody can make. This device continuously places more weights on one side of a drive shaft to give an unbalanced arrangement. This is done by placing expandable links between the weights. The links operate in a scissors-like mode which open up when the weights are rising, and contract when the weights are falling:

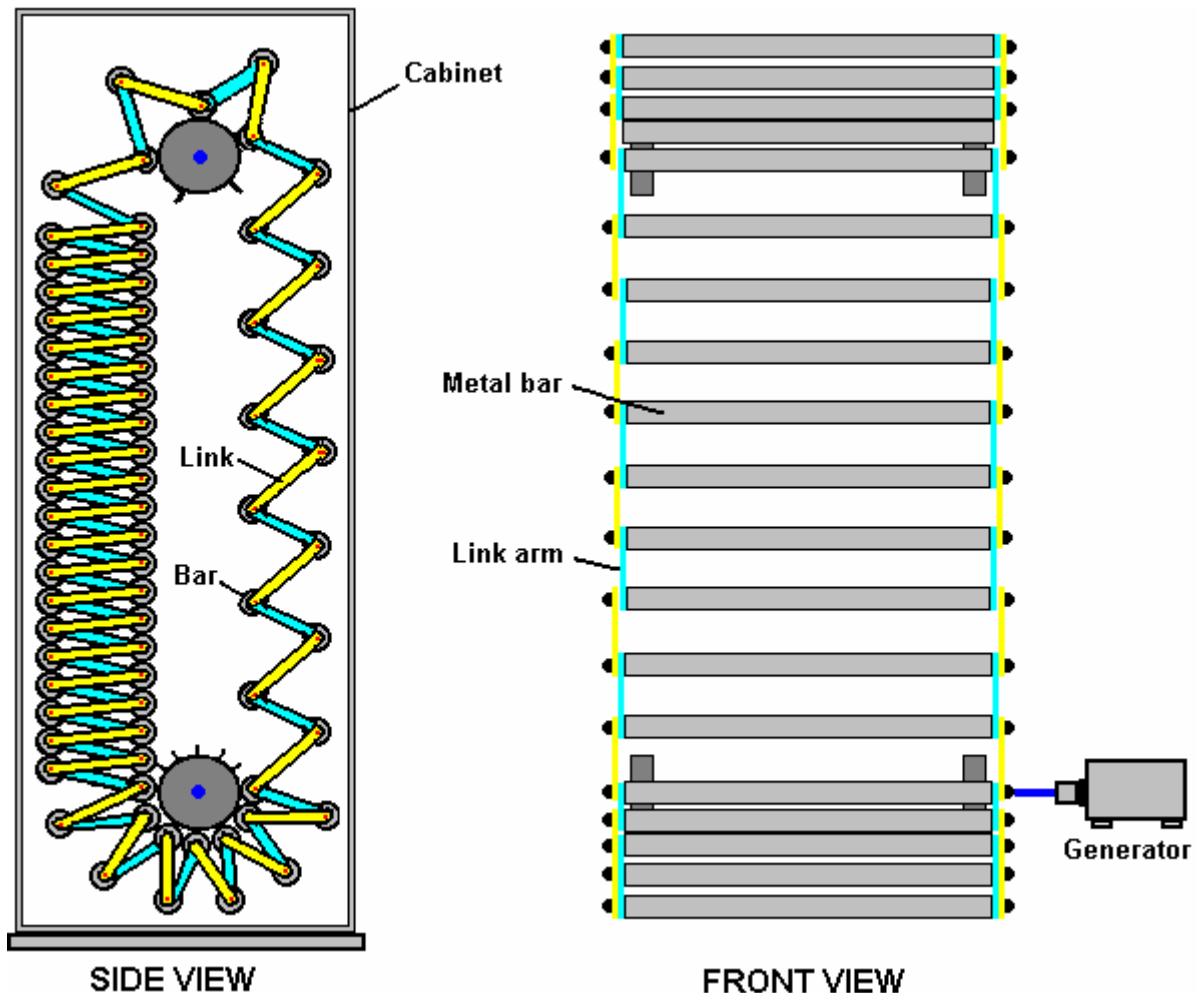

In the arrangement shown here, the weights are shown as steel bars. The design is scalable in both height, width and the mass and number of weights. In the rough sketch above, the practical details of controlling the position of the bars and co-ordinating the rotation of the two support shafts are not shown in order to clarify the movement. In practice, the two shafts are linked with a pair of toothed sprockets and a chain. Two sets of vertical guides are also needed to control the position of the bars when they are in-between the four sprockets which connect them to the drive shafts, and as they go around the sprocket wheels.

In the sketch, there are 79 bar weights. This arrangement controls these so that there are always 21 on the rising side and 56 on the falling side (two being dead-centre). The resulting weight imbalance is substantial. If we take the situation where each of the linking bars weighs one tenth as much as one of the bar weights, then if we call the weight of one link "W", the rising side has 252 of these "W" units trying to turn the sprockets in a clockwise direction while 588 of the "W" units are trying to turn the sprockets in an counter-clockwise direction. This is a continuous imbalance of 336 of the "W" units in the counter-clockwise direction, and that is a substantial amount. If an arrangement can be implemented where the links open up fully, then the imbalance would be 558 of the "W" units (a 66% improvement) and the level arm difference would be substantial.

There is one other feature, which has not been taken into account in this calculation, and that is the lever arm at which these weights operate. On the falling side, the centre of the weights is further out from the axis of the drive shafts because the link arms are nearly horizontal. On the rising side, the links are spread out over a lesser horizontal distance, so their centre is not as far out from their supporting sprocket. This difference in distance, increases the turning power of the output shafts. In the sketch above, an electrical generator is shown attached directly to one output shaft. That is to make the diagram easier to understand, as in practice, the generator link is likely to be a geared one so that the generator shaft spins much faster than the output shaft rotates. This is not certain as Murilo envisages that this device will operate so rapidly that some form of braking may be needed. The generator will provide braking, especially when supplying a heavy electrical load.

This diagram shows how the two side of the device have the unbalanced loading which causes a counter-clockwise rotation:

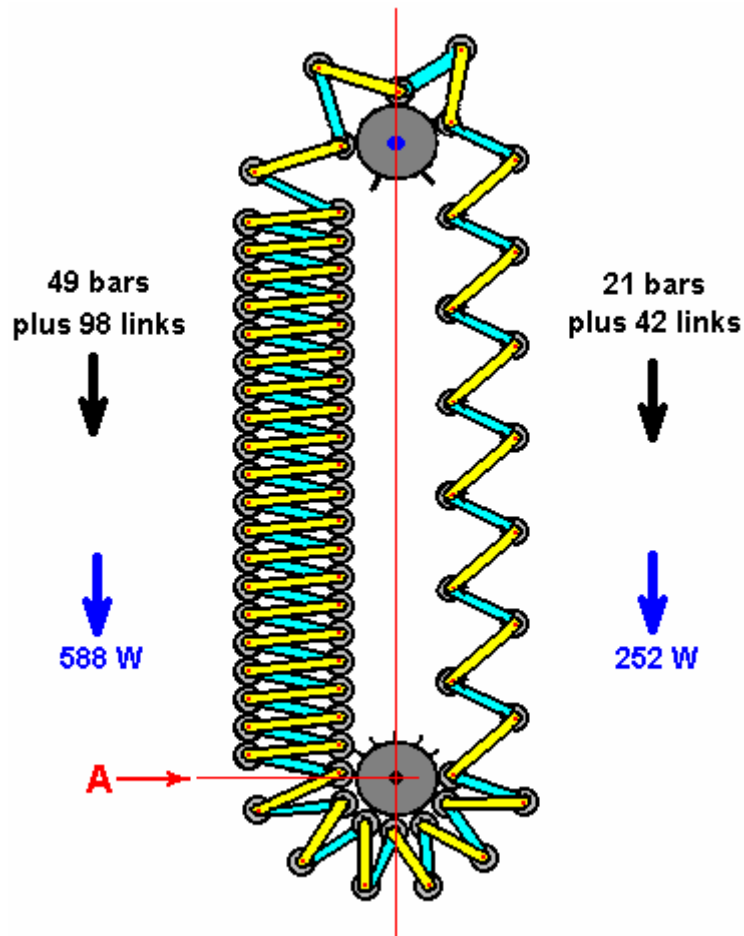

The diagrams shown above are intended to show the principles of how this device operates and so for clarity, the practical control mechanisms have not been shown. There are of course, many different ways of controlling the operation and ensuring that it works as required. One of the easiest building methods is to link the two shafts together using a chain and sprocket wheels. It is essential to have the same number of bar weights passing over the upper sprocket wheels as pass under the lower sprocket wheels. On the upper sprocket wheels, the bars are spread out, say, three times as far apart than they are on the lower sprocket wheels, so the upper sprockets need to rotate three times as fast as the lower ones. This is arranged by using a lower drive-chain sprocket wheel which has three times the diameter of the upper one.

The driving force provided by the weight imbalance of the two columns of rod weights needs to be applied to the lower sprocket wheels at point "A" in the diagram above. For this to happen, there has to be a mechanical connection between the stack of bar weights and the sprocket wheel. This can be done in different ways. In the above concept diagrams, this link has been shown as a sprocket tooth or alternatively, a simple pin projection from the sprocket wheel. This is not a good choice as it involves a considerable amount of machining and there would need to be some method to prevent the bar rotating slightly and getting out of alignment with the sprocket wheel. A much better option is to put spacers between the bar weights and have the sprocket teeth insert between the bars so that no bar slots are needed and accurate bar positioning is no longer essential. This arrangement is shown below:

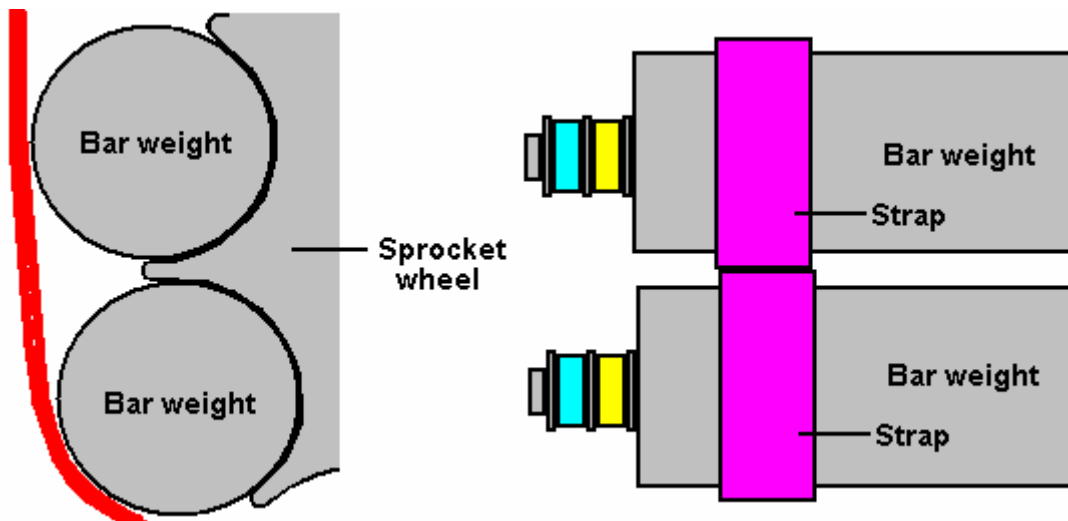
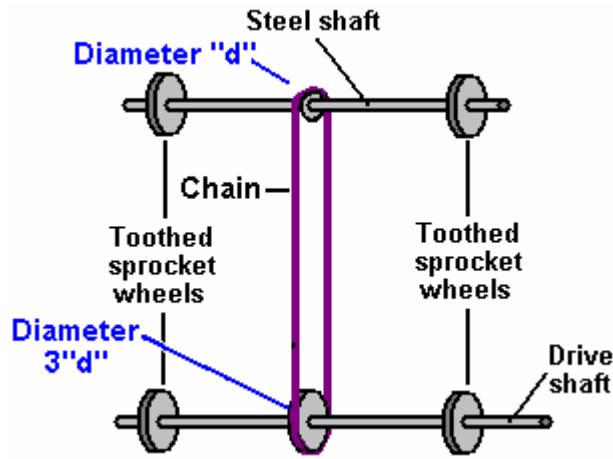

The description up to here has not mentioned the most important practical aspects of the design. It is now time to consider the rising side of the device. To control the expanded section of the chain, and to ensure that it feeds correctly on to the upper sprocket wheels, the gap between successive bar weights must be controlled.

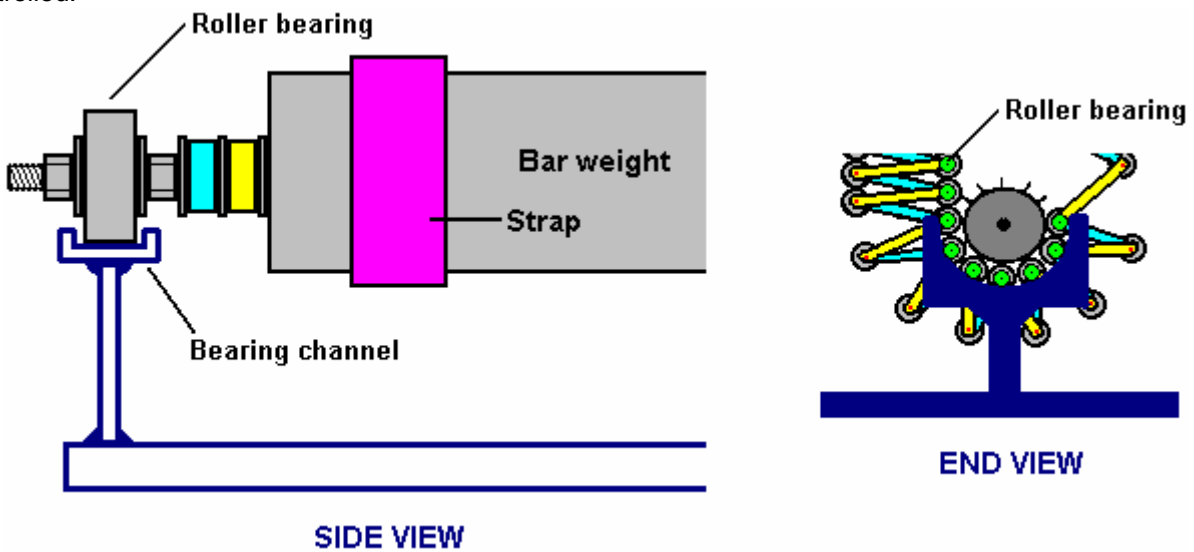

A guiding channel can be used, as shown here, and standard ball-bearings or roller-bearings can be attached to the ends of the weights by using threaded rod (or a bolt with the head inside the weight) and locking nuts.

In the example shown here, which is of course, just one option out of hundreds of different implementations, the bars on the rising side are three times as far apart as those on the falling side. This means that on the upper sprocket wheels, only every third tooth will connect with a bar weight. This is shown in the following diagram. However, if the linked weights were left to their own devices, then the rising side bars would hang down in one straight line. While that would be optimum for drive power, Murilo does not envisage that as a practical option, presumably due to the movement of the links as the bar weights move over their highest point. In my opinion, that arrangement is quite possible to implement reliably provided that the length of the links is selected to match the sprocket distance exactly, however, Murilo's method is shown here.

Murilo's method is to use additional restraining links between the weights. The objective here is to make sure that when the weights spread out on their upward journey, that they take up positions exactly three bar widths apart, and so feed correctly on to the teeth of the upper sprocket wheel. These links need to close up on the falling side and open up on the rising side. They could be fabricated from short lengths of chain or from slotted metal strips with a pin sliding along the slot.

Whichever method is chosen, it is important that the links stay clear of the bars and do not prevent the bars stacking closely together on the falling side as that would prevent them seating correctly on the teeth of the lower sprocket wheels. The easiest precision option for the home constructor is using chain, where two bar weights are positioned on the upper sprocket wheel to give the exact spacing, and the tensioned chain is welded in position, as shown below. Placing the chain inside a plastic tube causes it to take up an "A" shape standing outwards from the links when they move into their closed position. This keeps the chains from getting between the link bars. In addition, the chains are staggered from one pair of link bars to the next, as shown below, as an additional measure to keep the operation both reliable and quiet..

In the diagram below, only a few of these restraining links are shown in order to keep the diagram as simple as possible. It is not a good choice to make the upper bar sprocket wheels three times larger than the lower sprocket wheels as this would force both the rising and falling sections of chain out of the vertical, which in turn introduces friction against the guides. The central 1:3 gearing is needed to make sure that the chains on the rising side are fully stretched and the spacing of the bar weights matches the upper sprocket spacing exactly.

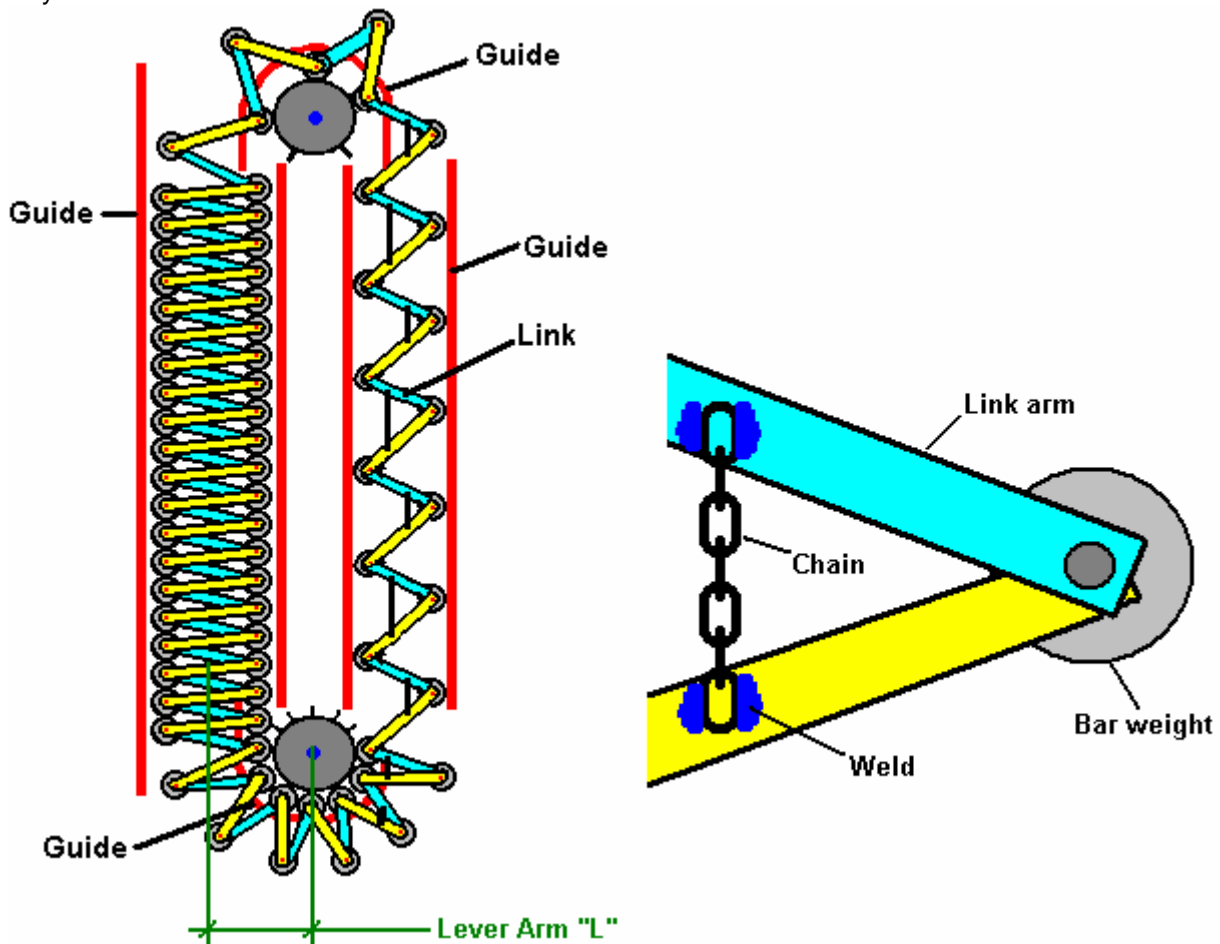

The diagrams have not shown the supporting framework which holds the axles in place and maintains the unit in a vertical position, as this framing is not specialised in any way, and there are many acceptable



variations. A sensible precaution is to enclose the device in an upright box cabinet to make sure that there is no chance of anything getting caught in the rapidly moving mechanism. This is an impressive design of Murilo's, who recommends that in the implementation shown above, that the links shown in blue are made 5% longer than those shown in yellow, as this improves the weight distribution and drive of the lower sprocket wheel.

A washing machine has a maximum power requirement of 2.25 kW and in the UK a suitable 3.5 kW alternator costs £225 and needs to be spun at 3,000 rpm for full output.

While the above description covers Murilo's main design, it is possible to advance the design further, raising its efficiency in the process as well as reducing the construction effort needed to build it. For this version, the main components remain the same, with the upper axle geared to the lower axle as before and the upper axle rotating faster than the lower one. The main difference is that on the rising side, the chain opens up completely. This does away with the need for the chain links, moves the rising weights much closer in and reduces the number of rising weights:

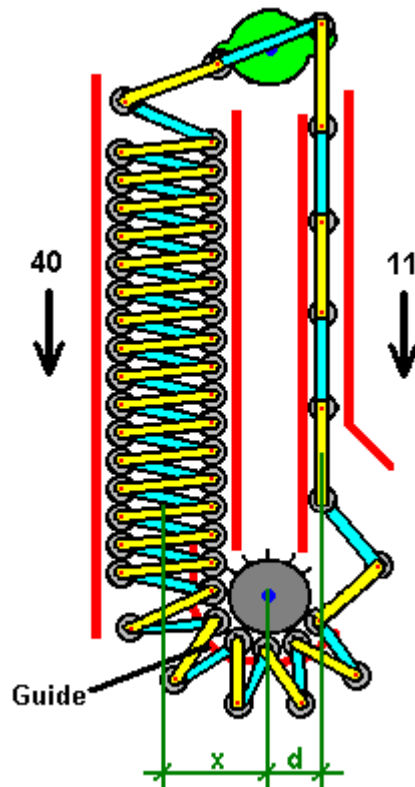

With a reduced number of weights in the diagram above, the weight imbalance is a very substantial 40:11 ratio with the massive advantage of a substantially reduced lever arm "d" which is much smaller than the lever arm "x" of the falling weights. This is a major imbalance, giving 40x pulling the axle in a counter-clockwise direction and only 11d opposing that movement.

In the description so far, it has been assumed that all components will be made of metal. This is not necessarily the best choice. Firstly, metal moving against metal does make a noise, so guides made robustly of thick plastic or other similar material would be a good choice for the guides for the weights.

The weights themselves could equally well be made from strong plastic piping filled with sand, lead pellets, concrete or any other convenient heavy material. The pipes would then have strong end caps capable of holding the pivots for the links. The sprocket wheels themselves could well be made from thick plastic material which would give a quieter operation and which could be bolted to the power take-off shaft with a bolt placed right through the axle.

Most of the dimensions are not critical. Increasing the diameter of the lower sprocket wheel will increase the power of the output axle but will lower its speed. Adding more weights will increase both the output power and to a lesser degree, the speed, but will increase the overall size of the unit and its overall weight and cost. Making each weight heavier will raise the output power, or reduce the overall size if the weight is contained in fewer weights. Increasing the length of the links means fewer weights on the rising side but will require larger sprocket wheels.

It is not necessary to have all the links the same size. If the lengths are chosen carefully and the indentations in the upper sprocket wheel cover the entire circumference, then every second link can be one indentation shorter which tips the weights into a more compact and effective column on the falling side:

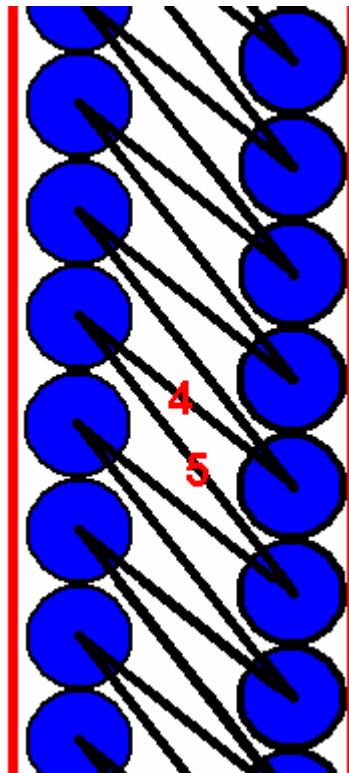
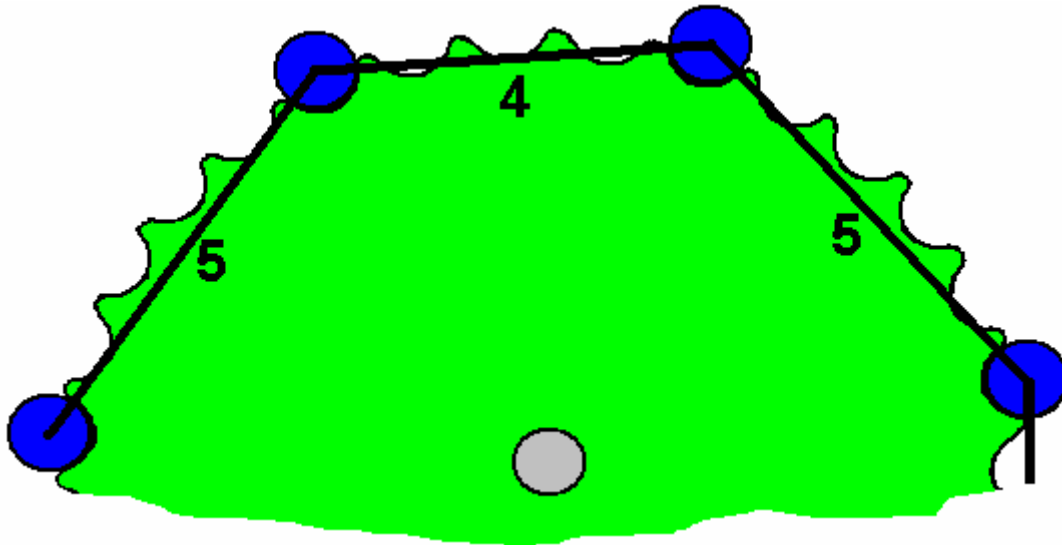

With this arrangement, the outer weights, shown here on the left, press down very firmly on the inside column of weights, making a compact group. If using plastic pipes with concrete then the hinge arrangement for the rods can be very simple, with a bolt set in the concrete as shown below.

The rods, washers and bolt can be supported on a thin, rigid strip placed across the top of the pipe. When the concrete has gone solid, the strip is removed and the gap produced by its removal then allows free movement of the rods. If this technique is used, then the bar weights are cast in two steps, with a tightly fitting disc pushed part way up inside the pipe so that one end can be filled while the other end remains open and ready for the completion of the other end.

One advantage of using plastic pipes is that if the sprocket wheels are made from a tough high-density plastic material, such as is used for food chopping boards, and the weight guides are also made from tough

plastic, then there should be no metal-upon-metal noise produced during operation, if the bolt holes in the connecting rods are a good fit for the bolts used.

The concrete or mortar used as a filling can be made wet and pliable, since mechanical strength is not an issue here, and a filling with no voids in it is desirable. Even low quality concrete (caused by more water than absolutely necessary) would be more than adequate for this purpose.

The arrangement at the ends of a concrete-filled plastic pipe bar weight could be constructed like this:

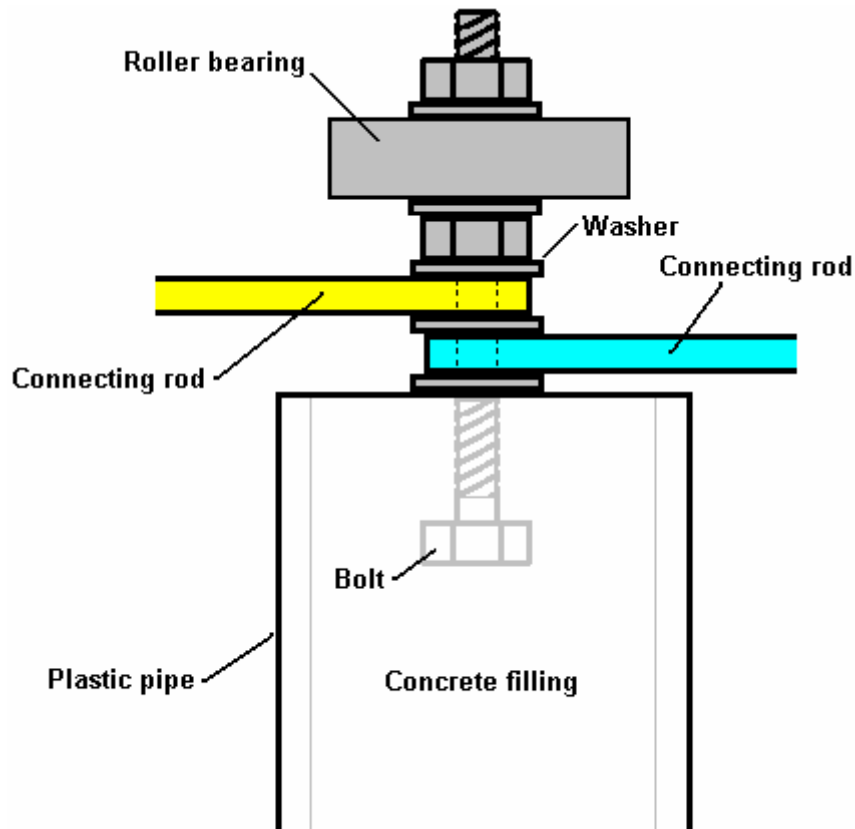

There is a very strong inclination when building a device to make it operate smoothly. Where excess energy is being drawn from the gravity field, the reverse is necessary, with a jerky operation being the optimum. Remember that the extra energy only occurs during the duration of the impulses causing the jerks. It follows then, that in an ideal situation, any device of this type should be driven by a rapid series of strong impulses. In practice, using a heavy flywheel or any similar component which has a high inertial mass, although a rapid series of sharp pulses is being applied to the component and jerky operation is not visible to the human eye, excess energy is still being "led-out" and made available to do useful work.

One other observation which may be of interest, and that is the feedback from builders of gravity wheels which says that the power output from a gravity wheel is greater if the axle is horizontal and the rotating wheel is aligned exactly with magnetic East-West.

### **A Practical Construction Query**

I have just been asked about the practical issues of mounting the guiding components for the weights. I must apologise for not making it clear that the diagrams in this description are intended to show the overall methods of operation, rather than being a direct construction arrangement. There will be several ways of constructing an implementation of each device. Here is one suggestion for a practical construction method for the gravity chain device.

The query was as follows:

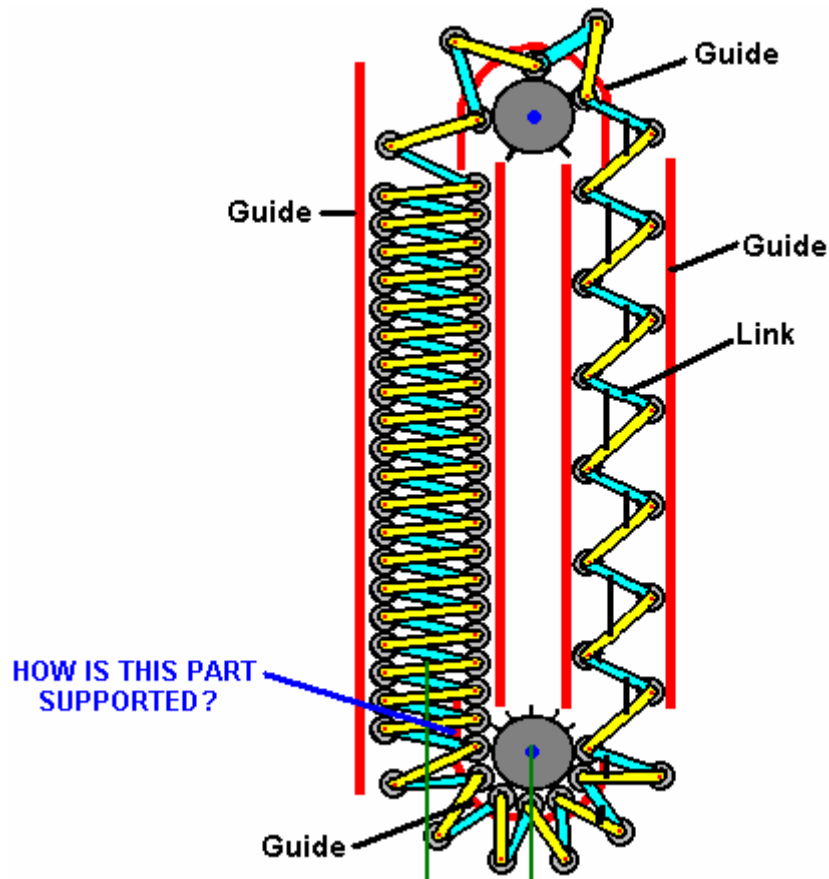

It is pointed out that the lower guide as shown, can't be supported from inside as the weights sweep through the area which would be used for that support. Also, it can't be supported from outside as the connecting rods have to move through the area where that support would be positioned. A solution has been suggested where the lower guide is supported by a strap from the upper guide, the strap running between the inner and outer weights. That is a solution which could work, but it introduces significant unnecessary friction. An alternative method is to place the guides outside the moving weights as shown here:

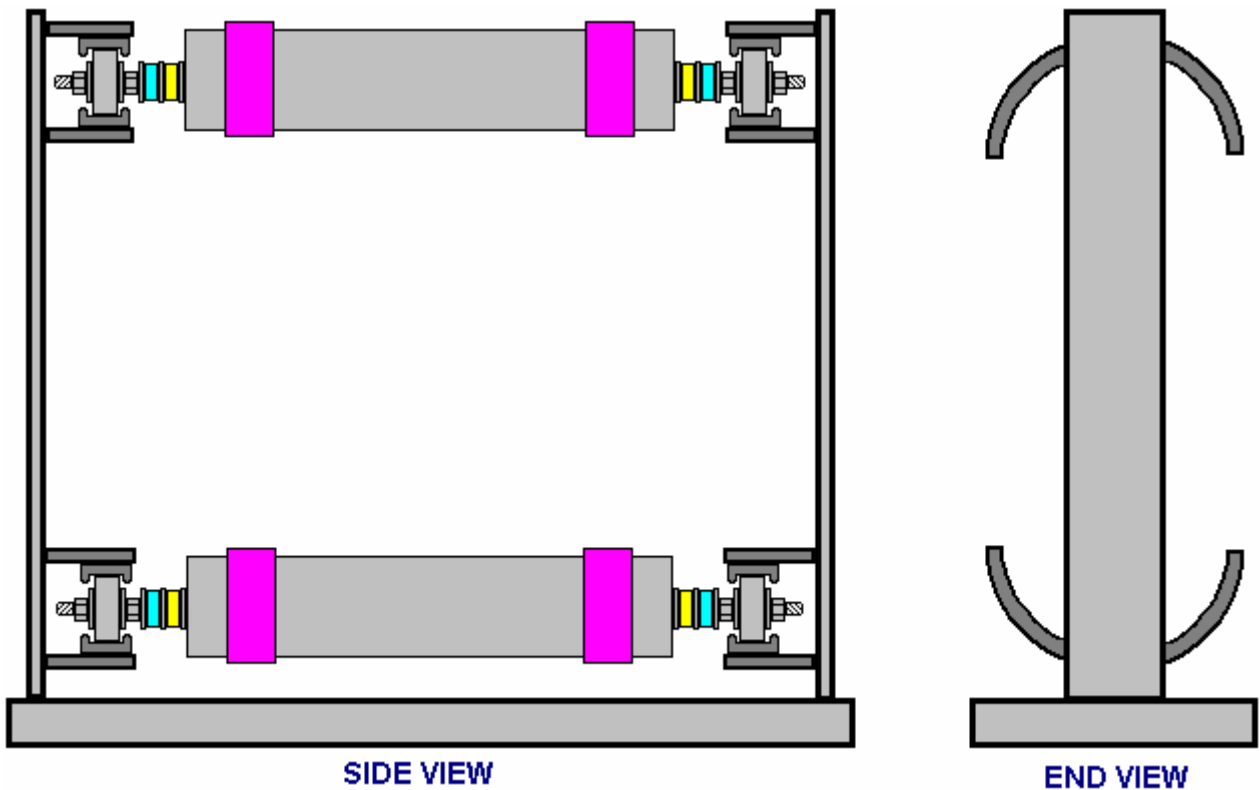

This method provides a low-friction channel for the roller-bearings to move along. This controls the position of the weights very accurately and the end walls also provide the supports for the axles which synchronise the positions of the weights and provide gearing between the axles if that is required. For clarity, just two of the many weights are shown and the overall proportions distorted so that the diagram will fit on the page.

With the axles, it might look like this:

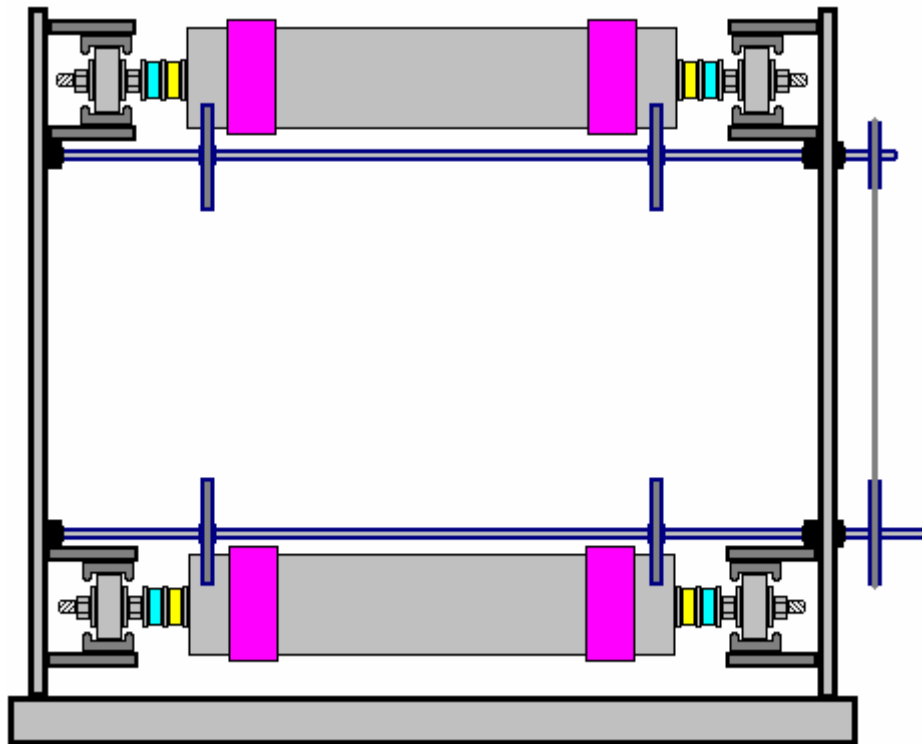

Here, the axle shafts are geared together outside the end wall and either a chain or a belt drive used. The lower shaft allows a power take-off. The ratio of the diameters of the pulley wheels or sprocket wheels dictates the relative rates of rotation of the two shafts.

### Other Gravity-Powered Designs.

Sterling Allan reports on **Bobby Amarasingam's** design which has 12 kilowatts of excess power: [http://pesn.com/2010/12/04/9501738\\_British\\_gravity\\_motor\\_generates\\_12\\_kilowatts/](http://pesn.com/2010/12/04/9501738_British_gravity_motor_generates_12_kilowatts/)

Also reported by Sterling is the **Smith-Caggiano** gravity/momentum/centrifugal-force generator design. The report is at: [http://www.peswiki.com/index.php/Directory:OBM-Global%27s\\_Angular\\_Force\\_Generator](http://www.peswiki.com/index.php/Directory:OBM-Global%27s_Angular_Force_Generator)

Another of Sterling's reports is on the **Chalkalis Gravity Wheel** which can be seen at: [http://peswiki.com/index.php/OS:F.\\_M.\\_Chalkalis\\_Gravity\\_Wheel](http://peswiki.com/index.php/OS:F._M._Chalkalis_Gravity_Wheel)

## Buoyancy

While we are aware of buoyancy being used to convert wave power into electricity, we seem to neglect the idea of using the very powerful buoyancy forces (caused by gravity) as a direct tool at locations away from the sea. This is definitely a mistake because serious levels of power can be generated from such a system. One such system is:

### The "Hidro" Self-Powered Generator of James Kwok.

This design demonstrates yet again, the practical nature of drawing large quantities of energy from the local environment. Commercial versions are offered in three standard sizes: 50 kilowatt, 250 kilowatt and 1 megawatt and licensing partners are being sought. This generator which James has designed can be seen at the Panacea-bocaf.org web site at <http://panacea-bocaf.org/hidrofreeenergysystem.htm> and on James' own web site at <http://www.hidroonline.com/> both of which have video clips explaining how the design works. The method is based on different pressures at different depths of water, gravity, and on the buoyancy of air-

filled containers. The system does not rely on wind, weather, sunlight, fuel of any type, and it can operate all the time, day or night, without causing any kind of pollution or hazard. This particular design calls for a water-filled structure of some height, a source of compressed air and a pulley system, and without wishing to be in any way critical, it seems rather more complicated than it needs to be. If, unlike James, you have not done the mathematics for the system, you would assume that the amount of power generated by a system like this would be less than the amount of power needed to make it operate. However, that is definitely very far from reality as considerable excess power is gained through the natural forces of the local environment which make the system operate. Part of the patent application which James made is shown here:

US 2010/0307149 A1

Date: 9th Dec. 2010

Inventor: James Kwok

**HYDRODYNAMIC ENERGY GENERATION SYSTEM**

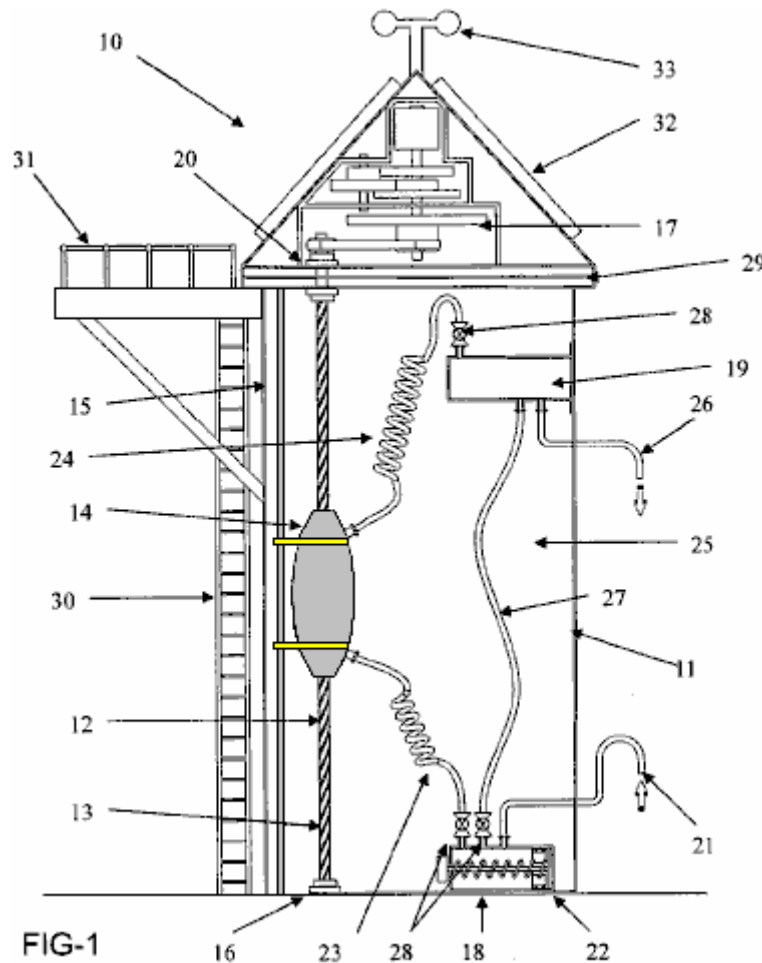

**Fig.1** is a cross-sectional view of an embodiment of the energy generation system of the present invention. Here, the energy generation system **10** comprises a vessel **11** in the form of a water tank and a shaft **12** which can rotate about its longitudinal axis. The shaft **12** is provided with a helical screw groove **13** and is connected at its lower end to a bearing **16** which allows it to rotate freely about its longitudinal axis.

The upper end of the shaft is connected to a generator **17** which is a flywheel system. The rotational energy of shaft **12** may be transferred to the generator through a ratchet-cog system **20**. A buoyant inflatable capsule **14** is provided along with its guiding mechanism **15** which is in the form of a wire or pole to assist in the smooth vertical movement of buoy **14**.

There is a first air reservoir **18** located in a lower portion of the vessel **11** and a second air reservoir **19** located in an upper portion of the vessel **11**. The first reservoir **18** draws air from the atmosphere, in through air intake port **21**. Once the pressure in the first reservoir has reached a predetermined value, a piston **22** is actuated, forcing air through hose **23** into the buoyant capsule **14**, which, when inflated, begins to move upwards through water tank **11**, as the buoy **14** has become less dense than the fluid **25** (such as fresh



Buoy 14 is attached to a guide pole 15 and the buoy has a pair of arms 39 which slide on the guiding pole 15 and assist in the smooth vertical movement of the buoy.

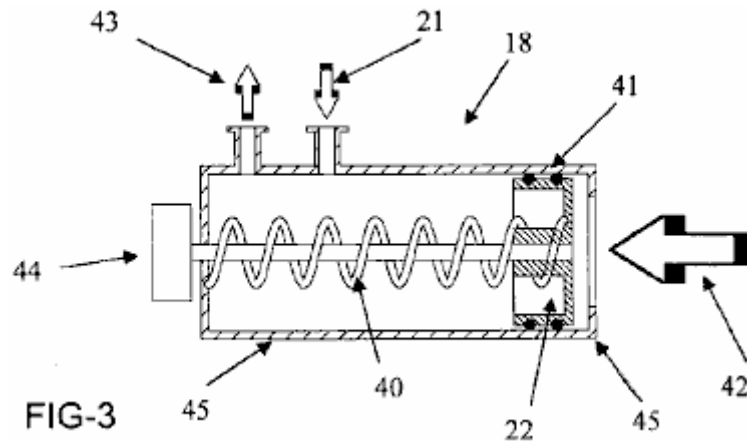

**Fig.3** shows one version of the first air reservoir 18. Air is drawn into reservoir 18 through air intake 21. The reservoir includes a piston 22 associated with a spring 40, the piston 22 being provided with seals 41 to prevent leakage of air.

When pressure, such as hydrostatic pressure, is applied in the direction of arrow 42, the piston moves to the left of the reservoir 18 compressing spring 40 and forcing air out through outlet 43. A motor 44 is provided to reverse the movement of the piston 22. Reservoir 18 may be fixed to the floor of the vessel.

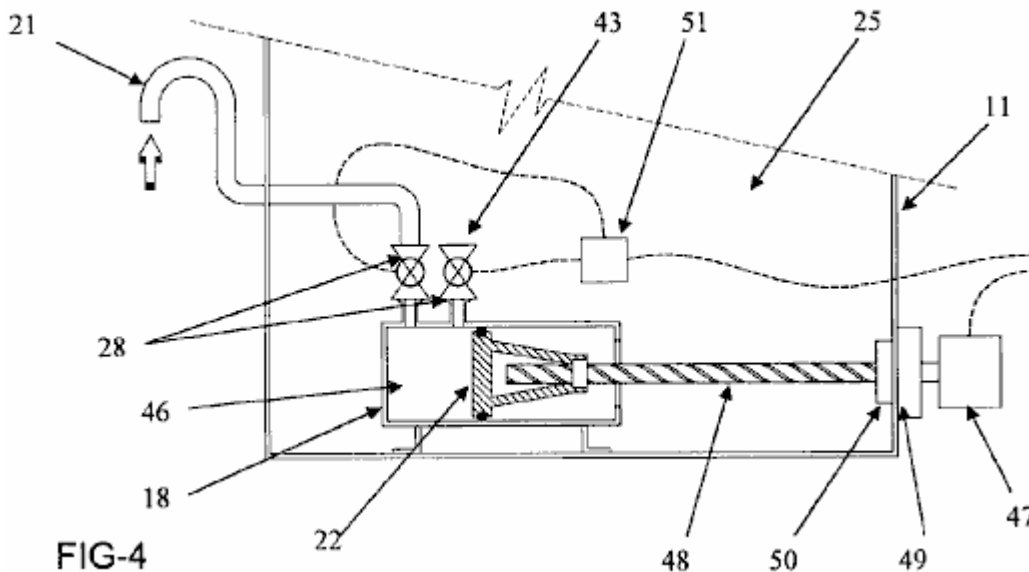

An alternative construction of the first air reservoir 18 is shown in **Fig.4**. In this embodiment, reservoir 18 is housed within a vessel 11 containing a fluid 25. Air enters reservoir 18 through air intake 21 and is held in a chamber 46. The reservoir has a piston 22 and the movement of the piston 22 towards the left of the reservoir 18 forces air in the chamber 46 out through air outlet 43.

Piston 22 is driven by motor 47 which rotates the helically-grooved shaft 48. The motor is linked to the shaft by a ratchet and cog mechanism 49, which is provided with a spring loaded seal 50 on the inner surface of vessel 11. An actuator 51, may be used to control the opening and closing of non-return valves 28 as well as the actuation of motor 47.

**Fig.5** illustrates a cross-sectional view of an energy generation system according to one of the embodiments of the present invention:



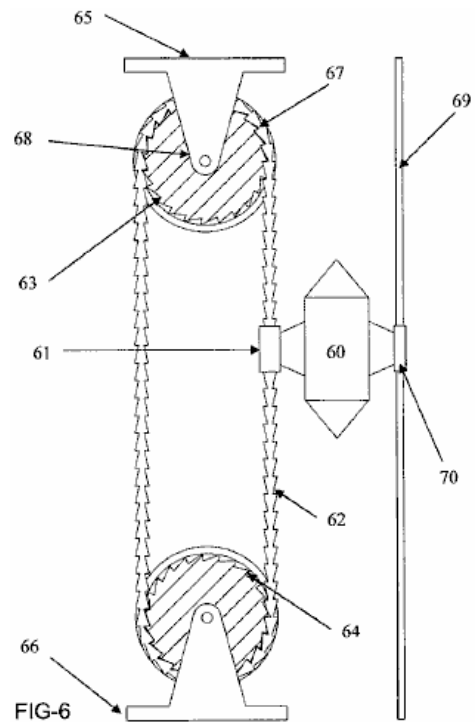
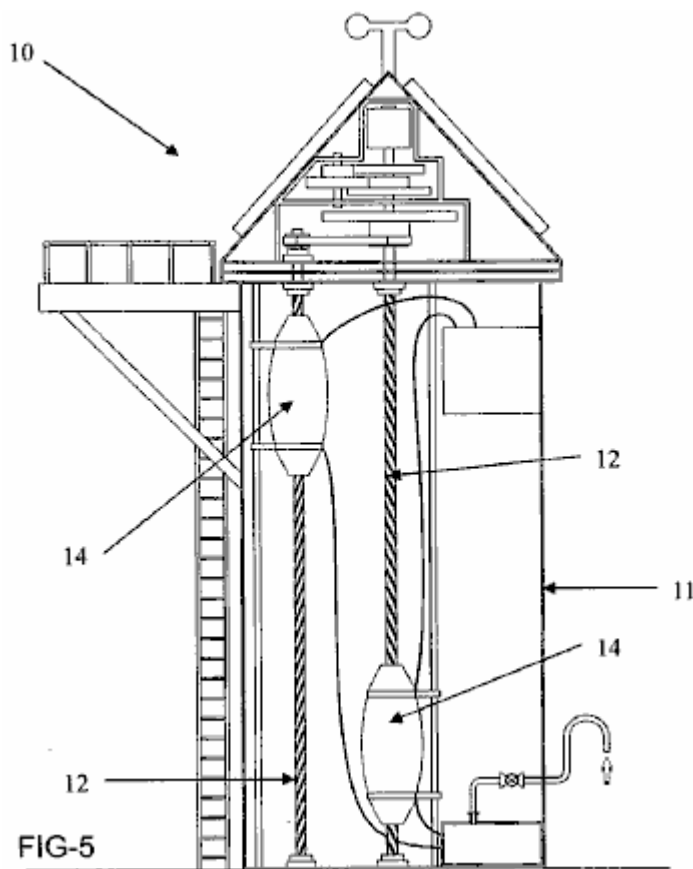
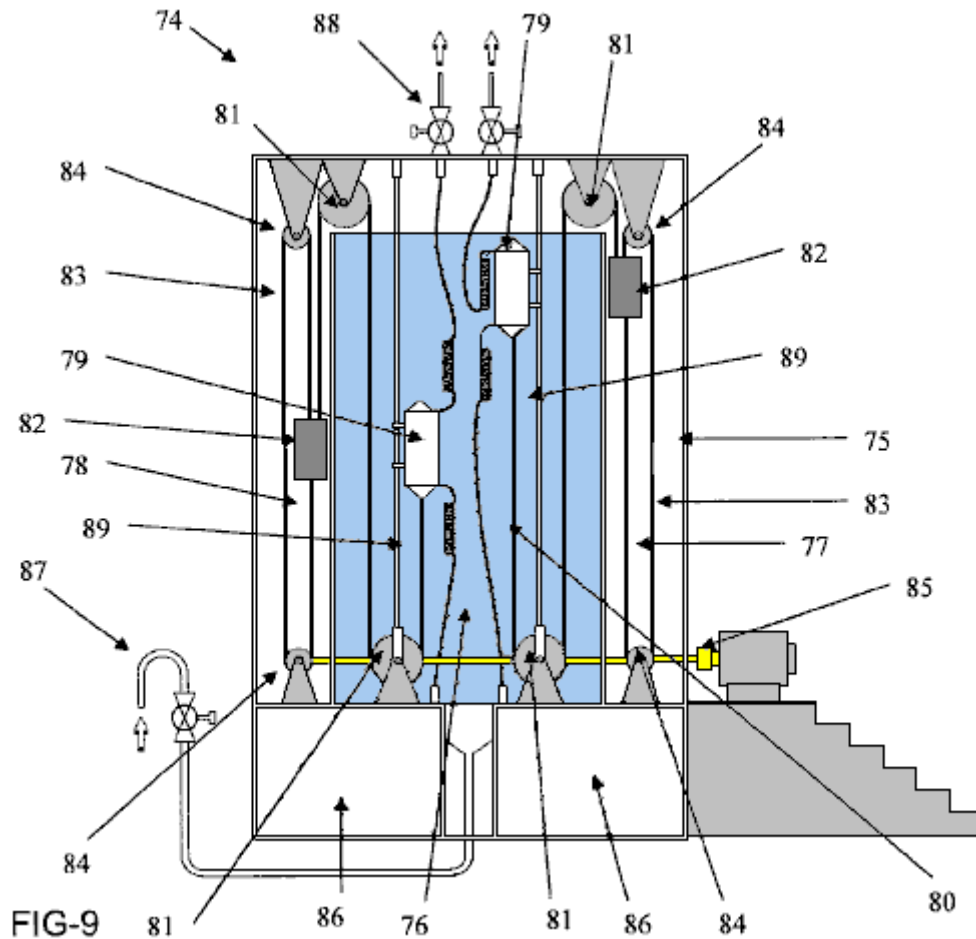

**Fig.5** shows an embodiment where which a pair of buoys **14** are present. Each buoy is associated with its own shaft **12** and may move up and down inside vessel **11** independent of one another.

In **Fig.6**, an alternative embodiment of the present invention is illustrated, where the buoy **60** has a connecting method **61** in the form of a cylindrical sleeve through which a guide chain **62** passes. Chain **62** is provided in an endless loop and is located on an upper tracking device **63** and a lower tracking device **64**, both of which are pulleys. The upper pulley **63** may be fixed to an upper wall (not shown) of a vessel (not shown) via a bracket **65**, while the lower pulley **64** may be fixed to a lower wall (not shown) of a vessel (not shown) via a bracket **66**.

The connection mechanism **61** contains ratchets which engage with the links of the chain **62** when buoy **60** moves downwards. Thus, as buoy **60** moves downwards, chain **62** also moves, thereby causing both the upper and lower pulleys to rotate in a clockwise direction. The upper and lower **64** pulleys have a series of indentations **67** corresponding to the shape of the links of the chain **62**. In this way, the chain **62** sits in the indentations **67** and grips the tracking device (**63, 64**), thereby ensuring that the tracking device (**63, 64**) rotates.

In the embodiment of the invention illustrated in **Fig.6**, a work shaft **68** is associated with the upper pulley **63** such that rotation of the upper pulley results in rotation of the work shaft **68**. The work shaft **68** is located substantially perpendicular to the direction of travel of the buoy **60**. The work shaft drives a generator to produce power.



**Fig.9** shows an alternative embodiment of this energy generation system **74**. The system is comprised of a vessel **75** having a fluid-filled “wet” compartment **76** and one or more “dry” compartments (in this case, a pair of dry compartments **77, 78**) with no liquid in them. These dry compartments may be fabricated from any suitable material, such as, concrete, steel, fibreglass, plastic or any combination of materials.

The system also has a pair of buoys **79** each with a deflatable bladder-like construction. The buoys have guide rails **89** which ensure that the buoys move smoothly up and down inside the vessel **75**.

In this embodiment of the invention, air reservoirs **86** are located in the base of the vessel **75**. Air enters the reservoirs **86** through inlet **87**, while air exiting from the buoy **79** is vented through valves **88**. The vented air may either be expelled to the atmosphere or recycled to the reservoirs **86**.

Each of the buoys is designed to be connected to one end of a chain or rope **80**. A weight **82** is connected to the other end of the chain or rope **80**. The chain or rope **80** has a series of pulleys **81** such that when the buoy is inflated and filled with air, the buoyancy is greater than the weight **82** and so the buoy rises in the vessel.

When the buoy **79** is deflated, weight **82** is heavier than the buoyancy and so the buoy sinks in vessel **75**. In the embodiment illustrated here, the weights **82** are located in the dry compartments **77,78**. There are several reasons for this, including that, by locating the weights **82** in the dry compartments **77,78**, the velocity of the weights **82** in the downward direction is increased, and therefore an increase in the energy produced by the system **74** is experienced.

The weights **82** are associated with second ropes or chains **83**, such that vertical movement of the weights **82** results in the rotation of the second ropes or chains **83** around a pair of sprockets **84**. Rotational energy generated by the rotation of the second ropes or chains **83** is transferred to a power generation device **85** (such as a turbine or the like) in order to generate power (e.g. electrical power)

\*\*\*

In spite of its mechanical complexity, the Hidro design is offered as a commercial generator with tens of kilowatts of excess power, indicating that buoyancy is a significant method of generating power, based on the fact that water is hundreds of times heavier than air. Due to its weight, movement in water is slow but can be very powerful. The helical groove method of converting the vertical movement of the floats into rotational power is used because of this as it has a very high ratio between shaft turns and movement along the shaft. This can be understood when you consider the fact that a complete revolution of the shaft is caused by the float moving up just one step to the next thread position directly above. The turns ratio for the complete float movement is determined by the angle of the groove cut into the drive shaft.

One other thing which needs to be considered for such a project is the weight of the overall structure when filled with water. The overall weight is liable to be many tons and so the footing underneath the generator needs to be very robust. Also, while compressed air is mentioned, giving the impression of cylinders of compressed air or gas, For continuous operation one would expect an air pump to be used. Whether or not an air pump is used, the diameter of the air hoses needs to be considered. Most people think that a gas can flow along a pipe or tube very easily. That is not the case. If you want to get a feel for the constriction caused by a pipe, then take a one metre length of 6 mm diameter plastic tube and try blowing through it. No significant amount of air will pass through the tube even if you blow very hard. The web site [http://www.engineeringtoolbox.com/natural-gas-pipe-sizing-d\\_826.html](http://www.engineeringtoolbox.com/natural-gas-pipe-sizing-d_826.html) shows this table:

Capacity of Pipe (MBH ≈ CFH)							
Pipe Size (inches)		Pipe Length (feet)					
Nominal	Inside diameter	10	20	40	80	150	300
1/2	0.622	120	85	60	42	31	22
3/4	0.824	272	192	136	96	70	50
1	1.049	547	387	273	193	141	100
1 1/4	1.380	1200	849	600	424	310	219
1 1/2	1.610	1860	1316	930	658	480	340
2	2.067	3759	2658	1880	1330	971	686
2 1/2	2.469	6169	4362	3084	2189	1593	1126
3	3.068	11225	7938	5613	3969	2898	2049
4	4.026	23479	16602	11740	8301	6062	4287
5	5.047	42945	30367	21473	15183	11088	7841
6	6.065	69671	49265	34836	24632	17989	12720
8	7.981	141832	100290	70916	50145	36621	25895

Notice the major difference in carrying capacity of any of these pipes with just the change from a 10-foot (3 metre) length to a modest 20-foot (6 Metre) length, and those lengths are the sort of lengths needed for many applications. Also, look at the figures for, say, the 0.5 inch (nominal) diameter pipe. With just a 10-foot length, it would take a full two minutes to pump just one cubic foot of air through it. It follows then, that pipes of considerably larger diameter are needed for a project like the 'Hidro'.

It is possible to construct a much more simple version of the 'Hidro', perhaps like this:

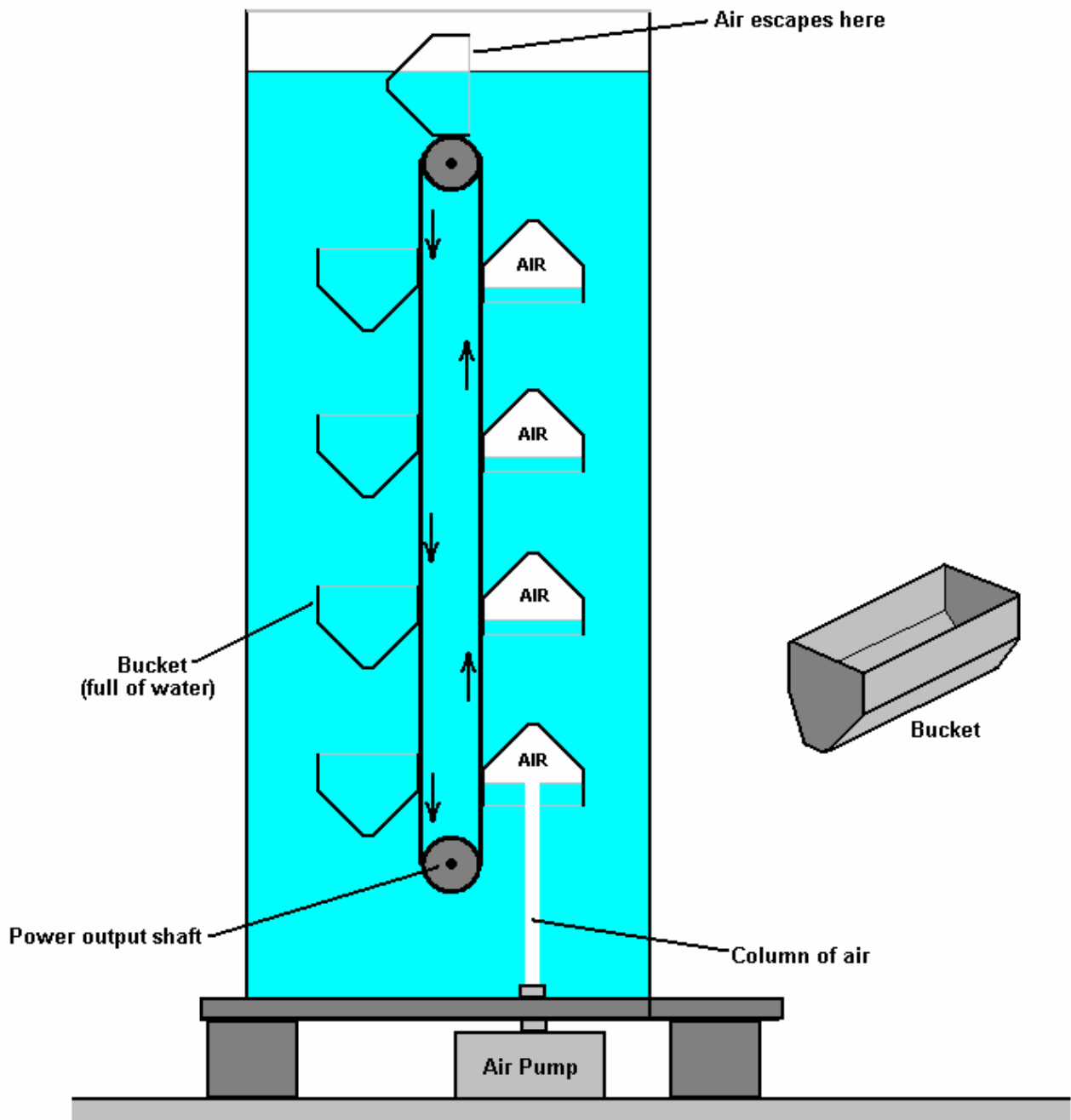

A simple hydraulic, buoyancy-powered generator can be constructed, with two or more horizontal, rotating shafts submerged in water in such a way that they are effectively positioned one above the other. Each shaft has one, and preferably two or more sprocket wheels mounted on it. Each of these sprocket wheels engages with a continuous chain loop which also engages with the sprocket wheel which is positioned vertically above it. These vertical chain loops form a belt-style support for a series of identical buckets. On one side of the vertical belt the buckets have their open face upwards and on the other side the bucket openings are facing downwards. An air pump is positioned directly underneath the set of buckets which have the bucket openings facing downwards. The air pump generates an upward-moving stream of air which collects in the rising buckets, displacing the water filling the bucket. This results in a powerful upward thrust caused by the buoyancy of that bucket, and the thrust causes the bucket to move upwards, rotating both horizontal shafts and bringing another water-filled bucket into position above the air pump. A gearing system transfers the rotation torque thus produced, to a generator which produces electricity for general purpose uses.

This is a generator whose input shaft is rotated through buoyancy caused by air-filled containers submerged in a tank of water or some other suitable heavy liquid. Continuous, powerful rotation of the generator shaft is produced through the use of one or more conventional, commercially available air pumps. An air pump is used to fill a series of containers which are open at one end and which are attached to what is effectively a belt arrangement created by two strong chain-link loops which mesh with sprocket wheels mounted on two

shafts, either, or both of which can be utilised for the extraction of useful power, preferably for driving an electricity generator but not necessarily limited to that function as any powerful torque has many useful applications.

Objectives are to provide a power generation system which is very simple in form and which can be understood, operated and maintained by people with minimal training. Also, a system which uses components which are already readily available, thus avoiding significant manufacturing costs, and one which operates without the need for any kind of complex mechanism or high-precision equipment and which can operate with a wide range of commercially available products.

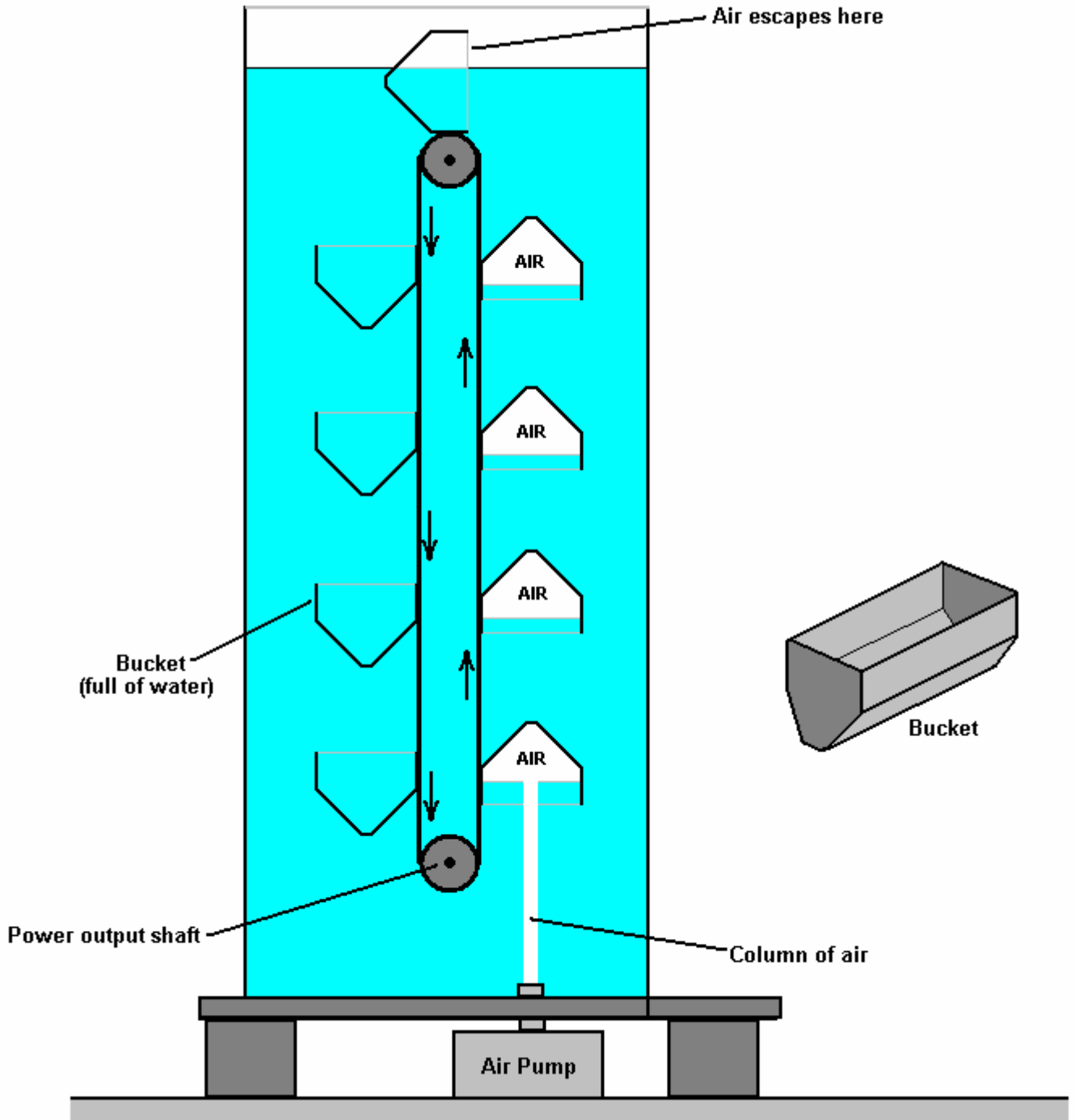

**Fig.1**, is a simplified partial schematic cross-sectional view showing the main components of the generator as seen from one end.



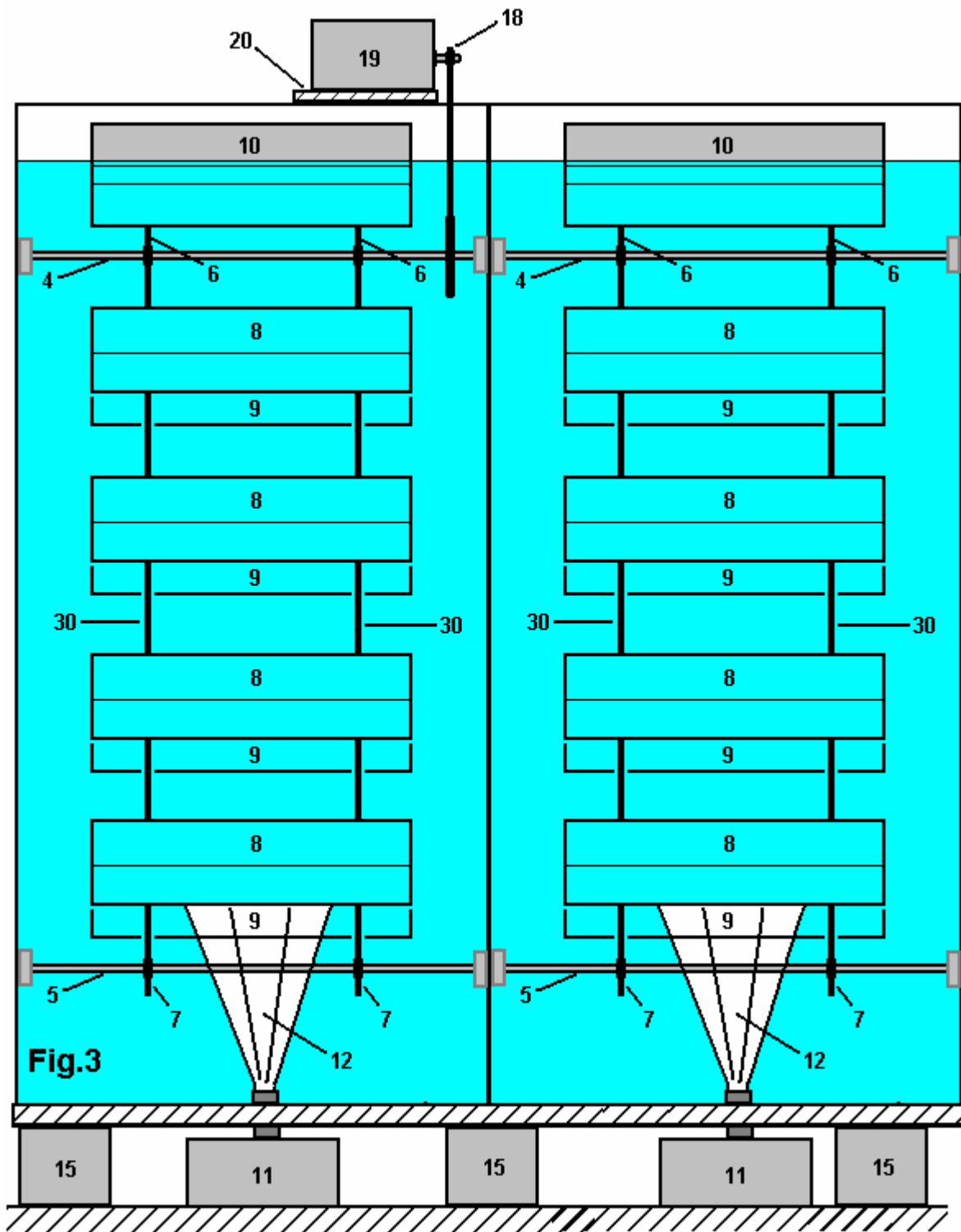

**Fig.3**

**Fig.3**, is a cross-sectional conceptual schematic view showing the frontal aspect of the generator where more than one set of buckets is used.

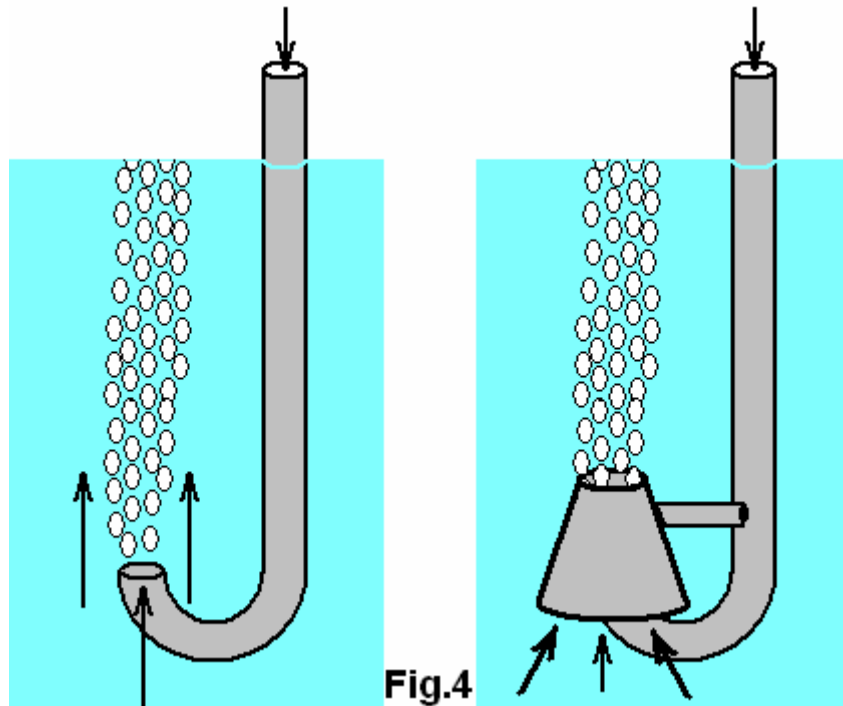

**Fig.4**

**Fig.4**, is a perspective conceptual view showing arrangements for a simplified air-feed system which operates from above the tank.

**Fig.1**, illustrates the overall concept of the generator in its most simple form where lightweight rigid buckets are used to capture the rising air from the air pump. In this Figure, a water tank **1**, holds water or other suitable liquid **2**. The surface of the liquid **3**, is indicated to illustrate the fact that a bucket **10**, which is in the process of turning over at the top of its orbital motion, is positioned so that one edge of the bucket is clear of the surface of the water, which allows the air which was trapped inside the bucket to escape into the atmosphere and the water fill the entire bucket causing only a very minor turbulence when doing so. This is a desirable, but not essential feature as the air trapped in any bucket will escape upwards as soon as the bucket starts its downward movement, positioning its open end upwards, although this causes unnecessary turbulence inside the tank. One possible bucket shape is shown in perspective view, but many different bucket shapes may be used, including flexible membrane types or alternatively, hinged-plate types which have very much reduced resistance to moving through the water when in their collapsed state during their downward movement.

The buckets **8**, **9** and **10**, are attached to two strong chains **30**, which mesh with the upper sprocket wheel **6**, mounted on the upper axle **4**, and the lower sprocket wheel **7**, which is mounted on the lower axle **5**. Although it is not visible in **Fig.1**, there are two upper sprocket wheels **6**, two lower sprocket wheels **7**, and two chain loops **30**, although these can be seen in **Fig.2**.

The tank is supported on a robust plate **14**, which itself is supported by a series of pillars **15** which rest on a secure footing **16**, providing operating space underneath the tank for the installation and maintenance of the air pumping equipment. As fresh water weighs 1000 Kg per cubic metre, the weight of the operational generator system is substantial and so this must be allowed for when assessing the footing needed to support the tank and it's contents. While a thin-wall tank is shown in **Fig.1**, many different forms of tank may be utilised, including earth bank and plastic membrane styles, or resurfaced abandoned well shafts. The tank of **Fig.1** presumes that the lower axle **5** is taken out through the wall of tank **1**, using an arrangement similar to that used for the drive shafts which power the screws of ships and other power vessels. While an arrangement of that type provides a drive shaft which is conveniently close to the ground, the much more simple arrangement shown in **Fig.2** where the output power is taken off using the very simple chain and sprocket wheel method utilised for the bucket supports (chain **30**, and sprocket wheels **6** and **7**). In general, the more simple and straightforward any design is, the better it works in practice and the lower any maintenance costs become.

Referring again to **Fig.1**, when activated, air pump **11** produces a stream of air **12**, which flows rapidly upwards. This stream of air **12**, once established, does not have to push against the head of water as immediately above the nozzle of the pump is a rapidly rising column of air, sustained both by the exit velocity from pump **11** and the natural upward movement caused by the relative weights of water and air (as water is



several hundred times heavier than air). This column of air would normally flow straight upwards in calm water, but should it be found that turbulence in the water tends to push the rising air away from its vertical path, baffles can be placed around the pump and positioned so that the air stream is forced to stay within the same section of water taken up by the rising buckets.

The rising air enters the lowest of the rising buckets and collects in it, forcing the water out of the open bottom of the bucket. If the rising bucket is not completely filled with air before the next bucket moves between it and the air pump, the trapped air will expand as the bucket rises and the water pressure reduces due to the lesser depth. Any one bucket with a substantial amount of air in it will create a very significant upward force due to buoyancy, air being about one thousand times lighter than water.

Each bucket on the rising side adds to that upward force and consequently, the chains **30** need considerable strength. The weight of the buckets on each side of the chain match and so the main advantage of light buckets is to lower the inertial mass of the moving parts. Movement through the water is relatively slow but this is offset by gearing between the output drive shaft and the generator's input shaft. The power of the system can be increased by adding more buckets in the vertical chain, increasing the water depth accordingly. Other ways of increasing the power include increasing the volume inside each bucket and/or increasing the flow rate produced by the air pump or pumps used. Another simple method is shown in **Fig.3** and discussed below. An alternative to air pumps is to use tanks of a compressed, non-polluting gas, possibly air.

The buckets shown in the various Figures are rigid, very simple shapes, possibly made by a plastic moulding process in order to be cheap, strong, lightweight and permanently water-resistant. There are, of course, many possible variations on this including using rigid hinged plates sealed with a strong flexible membrane, allowing the buckets to fold and become streamlined on their downward path, and opening as soon as they turn to start their upward movement. There are many mechanisms which can provide this movement, but it is a matter of opinion as to whether or not the extreme simplicity of rigid buckets is worth sacrificing

**Fig.2** shows a schematic layout of the generator when seen from the side. The same numbers apply to the components already seen in **Fig.1**. The arrangement seen in **Fig.2** is the most simple, basic, single bucket set. The near-side rising buckets **8** obscure the view of the far-side falling buckets **9** and only the lowest part of the falling buckets **9** can be seen in this view. **Fig.1** shows buckets which are some two and a half times longer than they are wide, but this, of course, is just one option among literally thousands of possible proportions. The size and shape of buckets is related to the performance and number of air pumps being used for any one set of buckets and that choice depends on what is available locally at a reasonable price. It would not be unusual for two or three air pumps to be used side by side along the length of the bucket **8** although **Fig.2** only shows a single pump.

**Fig.2** also shows a simple method for power take off where a large diameter sprocket wheel **16** is mounted on the upper axle **4**, and driving a much smaller diameter sprocket wheel **18** which is mounted on the drive shaft of the electricity generator **19** which is mounted on plate **20** which is attached securely to the top of tank **1**.

**Fig.3** shows one of the possible arrangements for increasing the system power without increasing the depth of water used. Here, the axles **4** and **5** extend far enough to allow another set of buckets to drive them, increasing the torque very substantially. While **Fig.3** shows one extra set of buckets, there is, of course, no reason why there should not be three or more sets of buckets side by side. It should be noted however, that the partitions shown between the bucket sets are not there just to reduce the water swirling but are needed to support the bearings which are essential for the extended axles, since without those, the diameter of the bars used for the axles would have to increase very markedly to avoid unwanted flexing along their length. While the second set of buckets has been shown aligned exactly with the first set, there is an advantage in offsetting them relative to each other so that the output torque is more even with buckets emptying and filling at different points in the bucket cycle.

**Fig.4.** shows a method for further simplification, where the air is pumped from above the water surface. It is a matter of concern to most people, that the pressure of the head of water above the air pump is a major obstacle to overcome and will be a continuous opposing force during operation of the generator. If air is being injected from underneath the tank, then initially, that pressure head has to be overcome. However, once the air flow is established, a vertical cigar-shaped area of water vortex is established by the rising air stream. This three-dimensional annular vortex negates the water head in the small area immediately above the air nozzle, and almost sucks the air out of the pump, after the initial introduction of the air has been accomplished.

There is another way of achieving this desirable effect without ever having to pump against the total head of water, and that is to use a mobile air pipe as shown in **Fig.4**. Initially, the air pump is started and lowered a short distance into the water. The opposing head of water is not large and the water vortex can be established quite easily. The pipe is then lowered very slowly, so as to maintain the vortex at a progressively lower depth, where, in spite of the increased head of water, the pump does not have to overcome that head. When the pipe outlet reaches the operational depth, it is then rotated to bring it under the set of rising buckets. The major advantage of this arrangement is that the tank is as simple as possible, with no possibility of leaking, and so abandoned wells can be modified to become energy generators. Alternatively, an earth bank can be erected to form an above-ground tank, possibly sealed with a plastic membrane. This method also avoids needing to support the weight of tank and water above a work-area where the air pump or compressed-air cylinders are located and maintained. The creation of the water vortex can be assisted by the addition of a cowl around the pipe exit as shown in this figure, but that is an optional feature.

### **The Ribero Buoyancy Patent.**

While internal combustion engine demonstrate that considerable power can be had from motion which moves backwards and forwards continuously, that sort of action is not very efficient as there is continuous reversal of the oscillating drive components. The floats in the (very successful) 'Hidro' design shown above. A different design is shown in the 2011 patent of Renato Bastos Ribero of Brazil. Here is an excerpt from that patent:

**US 7,958,726**

**14<sup>th</sup> June 2011**

**Inventor: Renato Bastos Ribero**

### **Apparatus and associated methods to generate useable energy**

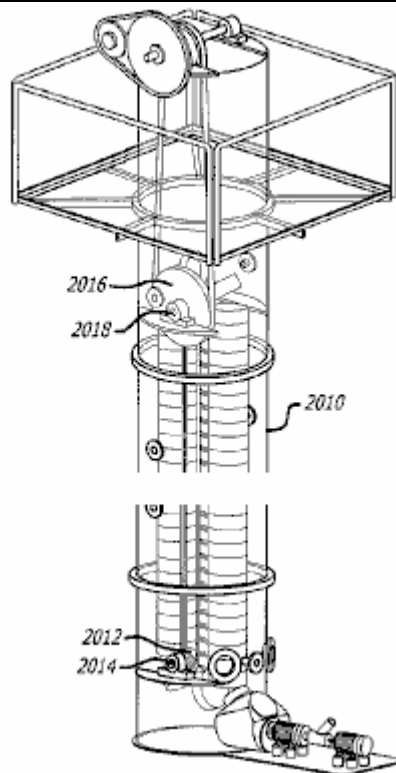

### **Abstract:**

The present disclosure relates to an apparatus and associated methods for generating energy by capturing and taking benefit of the energy generated by any quantity of air surfacing inside water. In exemplary embodiments, the apparatus comprises compressing a lower density gas in a liquid medium, allowing the gas to naturally rise to the surface of the liquid medium and then capturing the energy generated by the surfacing gas.

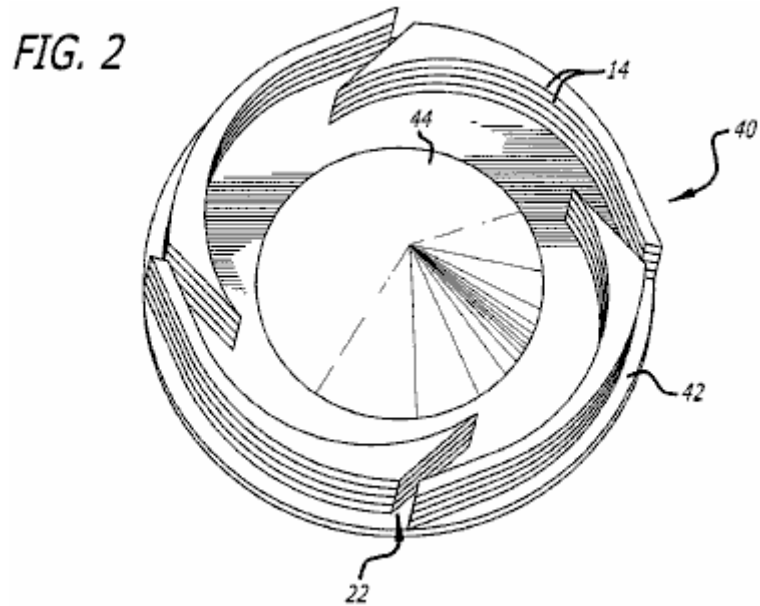

**Fig.2** is a perspective upper view of a rotor disc for compressing a gas into a liquid medium. This disclosure is in two stages which, in this case, work together. The first stage consists of the creation of energy with the introduction of air at the bottom part of a water column. Once introduced, the air creates energy when moving towards the surface. The introduction of air into the water is the main point of this first part of the disclosure. A method was created in order to use a very small quantity of energy when doing this.

The teeth on the disc, when rotated in water, water to flow away from the area between the teeth, lowering the pressure there and allowing the easy introduction of air in that area. Without air introduction, water would not move away and the pressure would not be reduced. The purpose of the cone is to spread the incoming air.

The second section of the present disclosure refers to a system with the objective of capturing the air which is inserted at the bottom of a water column or tank, while moving towards the water surface.

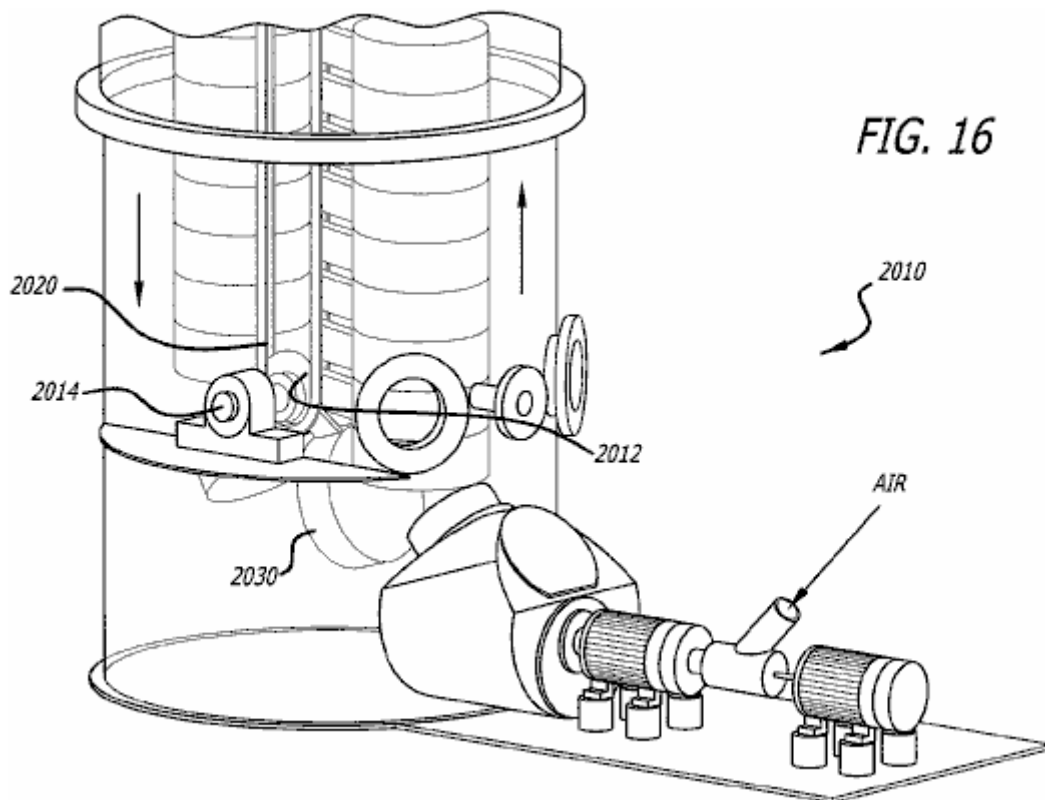

As shown in **Fig.16**, buckets **2030** descend on a continuous chain **2020** which passes around a lower and an upper wheel or pulley. On reaching the lower pulley, the buckets turn around the bottom pulley **2014** and line up again on the ascending side of the chain. Immediately after turning around the bottom pulley, each bucket receives the rising airflow.

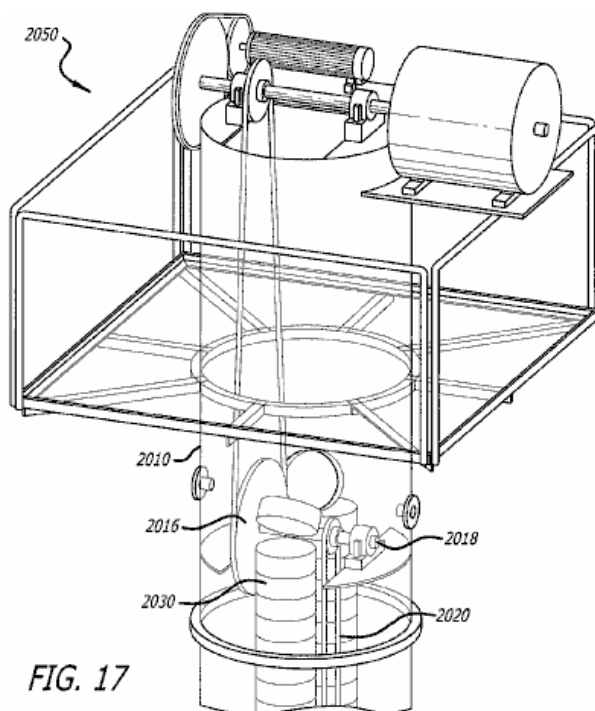

**FIG. 17**

**Fig.17** shows the arrangement at the top of the water tank **2010**. Buckets **2030** rising due to being filled with air, turn over as they pass around the top pulley **2018**, releasing the air inside them and start descending again towards the bottom pulley. The upper axle **2018** has an **estimated** rotational speed of 120 rpm.

In Fig.17 I (Riberio) am showing the transmission of this energy to an axle at the top of the water column where we have a generator **2050** requiring a rotation of 300 rpm plus an engine connected to another generator with rotation of 600 rpm. This part of Fig.17 is only illustrative to show that we **shall** generate energy at the primary axle at 120 rpm, or use any kind of transmission to more convenient rotational speeds.

\*\*\*

I think that the words marked in red indicate that although this patent has been granted, the generator has never been built and is only an idea. Personally, I am highly dubious about the mechanisms which are supposed to give reduced water pressure at the air intake, as I don't think that they would work, or if they do, certainly not for the reasons stated. What he wants to do can certainly be done, but not in the way that he suggests. If the axles are rotating at the 120 rpm which he suggests, then that would allow less than one eighth of a second to fill each bucket and while the notion of reduced water turbulence through the buckets touching each other is attractive, I don't think that the method described is feasible.

So, while we can be sure that buoyancy methods are perfectly capable of generating serious power, we need a better design than either of the two shown here as the Hidro appears to be very expensive to build.

Patrick Kelly  
<http://www.free-energy-info.co.uk>  
<http://www.free-energy-info.com>  
<http://www.free-energy-devices.com>  
[engpjk@free-energy-info.co.uk](mailto:engpjk@free-energy-info.co.uk)  
[engpjk@gmail.com](mailto:engpjk@gmail.com)